

**Figure 8.3.2** Typical Section of a Stress-Laminated Timber Slab Bridge



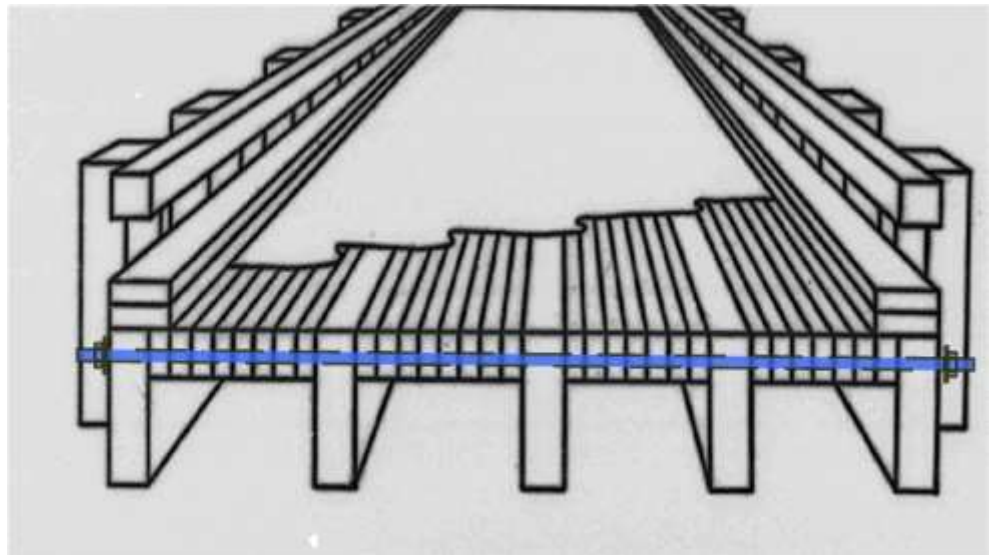
**Figure 8.3.3** Stress-Laminated Timber Slab Bridge



**Figure 8.3.4** Glulam Stress-Laminated Timber Slab Bridge

**Stress-Laminated  
Timber Tee Beam  
Bridges**

The idea for stress-laminated timber tee beam bridges was developed at West Virginia University. These bridges consist of a stress-laminated deck and glulam beams (see Figure 8.3.5). High strength steel rods are used to join the stress-laminated deck and glulam beams together to form stress-laminated timber tee beams. The first structure of this type was built in 1988, near Charleston, West Virginia. It is 75 feet long and has stressing rods spaced at two feet. This bridge has performed well, which encouraged longer span lengths to be constructed. The average span length for stress-laminated tee beam bridges ranges between 25 and 85 feet (see Figure 8.3.6).



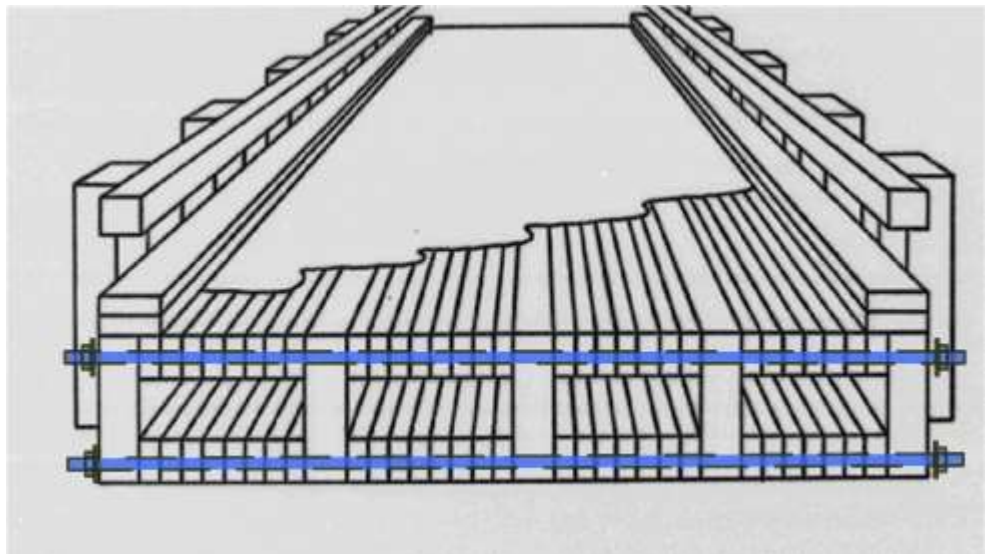
**Figure 8.3.5** Typical Section of a Stress-Laminated Timber Tee Beam Bridge  
(Source: Barry Dickson, West Virginia University)



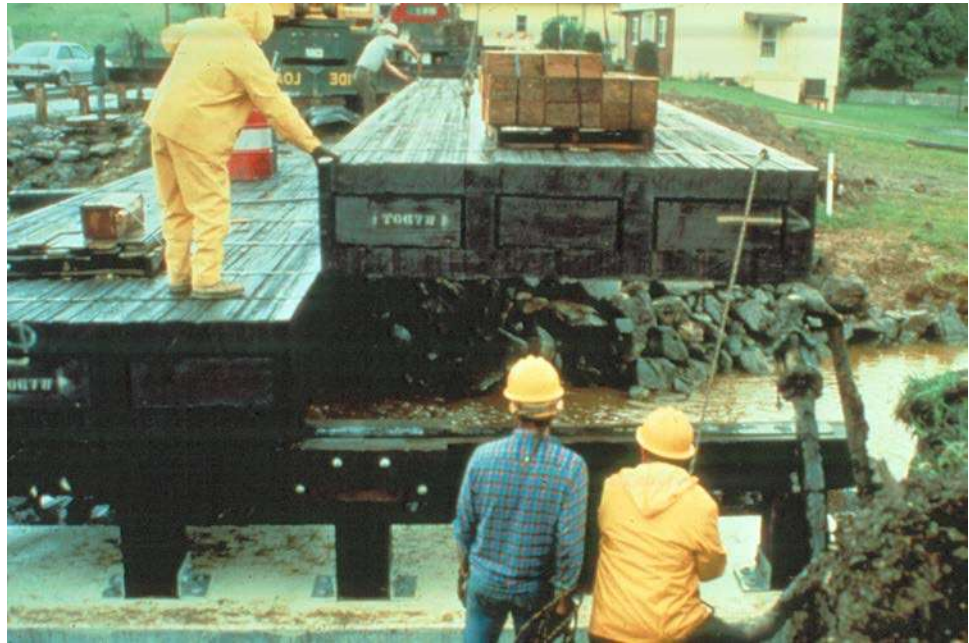
**Figure 8.3.6** Elevation View of Stress-Laminated Timber Tee Beam Bridge (West Virginia)

### **Stress-Laminated Timber Box Beam Bridges**

Stress-laminated timber box beam bridges represent further development of timber bridges by West Virginia University. These bridges consist of adjacent box beam panels individually comprised of stress-laminated flanges and glulam beam webs (see Figure 8.3.7). This bridge type is also known as a cellular stressed deck. Average span lengths range between 35 and 65 feet, with longer maximum spans (see Figure 8.3.8).



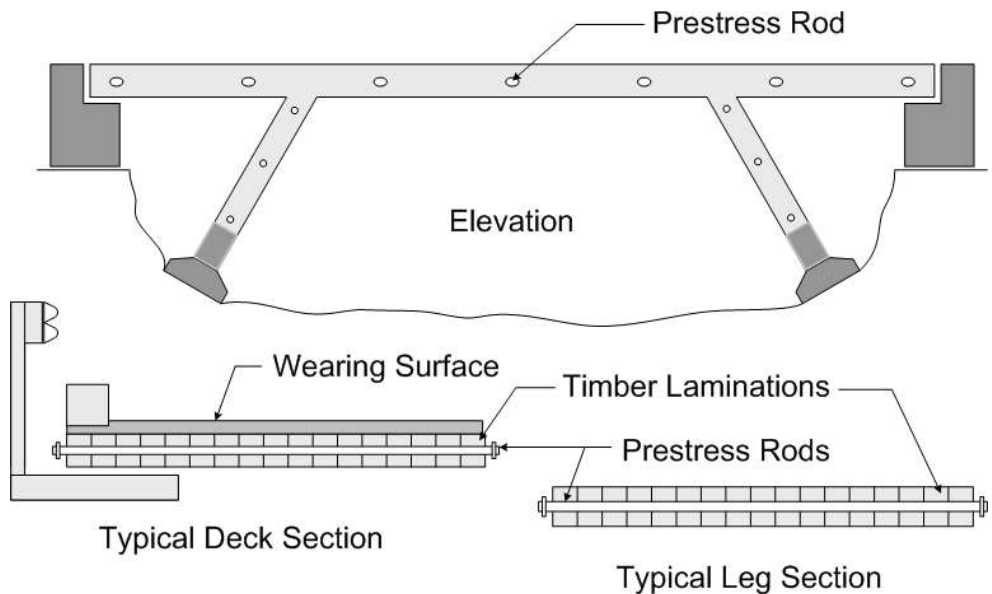
**Figure 8.3.7** Typical Section of a Stress-Laminated Timber Box Beam (Source: Barry Dickson, West Virginia University)



**Figure 8.3.8** Stress-Laminated Timber Box Beam Bridge Being Erected

**Stress-Laminated  
 Timber K-frame  
 Bridges**

Stressed K-frame bridges represent further development of the stressed deck bridge by the Ontario Ministry of Transportation and Communications. These bridges consist of three spans in which the stressed deck is supported at two intermediate points by stressed laminated timber struts (see Figure 8.3.9). This bridge type has been used for a bridge with a total length of excess of 100 feet, and it has a potential for center span lengths over 50 feet.



**Figure 8.3.9** Stress-Laminated Timber K-frame Bridge

**Primary and Secondary  
 Members**

The primary members are the decks, slabs, tee beams, box beams, and frame legs. The secondary members are the external diaphragms and cross bracing between beams.

### 8.3.3

---

#### Overview of Common Deficiencies

Common deficiencies that occur on stressed timber bridges include:

- Inherent defects - Checks, splits, shakes
- Decay by fungi
- Damage by insects and borers
- Loose connections
- Loose or deteriorated stressing rods or connectors
- Surface depressions
- Damage from fire
- Damage from impact/collisions
- Damage from wear, abrasion, and mechanical wear
- Damage from overstress
- Damage from weathering/warping
- Failure of protective system

A less common deficiency that may be encountered by the inspector includes damage from chemical attack. Refer to Topic 6.1 for a more detailed presentation of the properties of timber, types and causes of timber deterioration, and the examination of timber.

### 8.3.4

---

#### Inspection Methods and Locations

Inspection methods to determine other causes of timber deterioration are discussed in detail in Topic 6.1.7. The inspection of stress-laminated timber bridges is similar to those for glulam bridges.

#### Methods

##### Visual

The inspection of timber for checks, splits, cracks, shakes, fungus decay, deflections, crushing, delaminations, and loose connections is primarily a visual activity.

##### Physical

The physical examination of a timber member can be conducted with a hammer or pick. The hammer is used to sound the members to detect hollow areas or internal decay. Picks are used to determine the condition of the surface.

##### Advanced Inspection Methods

Several advanced methods are available for timber inspection. Nondestructive methods, described in Topic 15.1.2, include:

- Sonic testing
- Spectral analysis
- Ultrasonic testing
- Vibration

Other methods, described in Topic 15.1.3, include:

- Boring or drilling
- Moisture content
- Probing
- Field ohmmeter

## Locations

### Stressing Rods

Examine the condition of the steel stressing rods, and inspect for crush and splits in the fascia members. Check for loss of prestress in the rods, which would be indicated by shifted planks in the stress-laminated timber element and excessive deflection or loose rods. This may be observed when the bridge is subject to a moving live load.



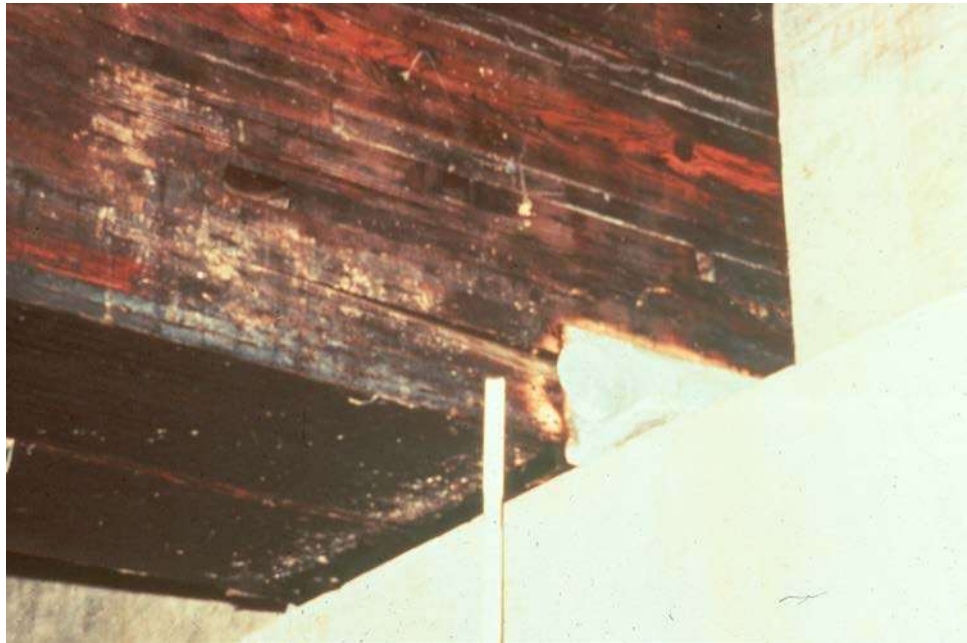
**Figure 8.3.10** Broken Stressing Rods

### Bearing Areas

Inspect the bearing areas for crushing of the beams. Investigate for decay and insect damage by visual inspection, sounding, and/or probing at the ends of the beams. Also check the condition and operation of the bearing devices if they are present (see Topic 11.1, Bearings).

### Shear Zones

Examine for horizontal shear cracks and delaminations near the ends of the beam. Delaminations (i.e., separations in the laminations) can occur due to either failure of the glue or failure at the bond between the glue and the lamination (see Figure 8.3.11). Delaminations that extend completely through the cross section of the member are the most severe since this makes the member act as two smaller members.



**Figure 8.3.11** Close-up View of End of a Stress-Laminated Timber Bridge Showing Laminations

### Tension Zones

Examine the zone of maximum tension for signs of structural distress. The maximum tension generally occurs at the bottom half of the middle third of the beam span. Investigate for section loss due to decay or fire, especially near mid-span. Inspect for excessive deflection or sagging in the beams.

### Areas Exposed to Drainage

Investigate for signs of decay along the full length of the member but especially where the beam is subjected to continual wetness or prolonged exposure to moisture. Decay and chemical attack may be evidenced by discolored wood, brown and white rot, the formation of fruiting bodies (the result of fungal attacks, which produce disc-shaped bodies that distribute reproductive spores), "sunken" faces in the wood, or the soft "punky" texture of the wood. Examine the curb line areas. Standing water soaks into the beam and corrodes the stressing rods.

### **Areas of Insect Infestation**

Insect infestation can be detected in various ways. Carpenter ants generally leave piles of sawdust; powder-post beetles leave small holes in the surface of the wood; and termites can often be readily seen. Another indication of insect infestation is hollow sounding wood. Perform further probing or drilling in suspect areas.

### **Areas Exposed to Traffic**

Check stress-laminated timber members for collision damage from vehicles passing below.

### **Areas Previously Repaired**

Thoroughly examine any repairs that have been previously made. Determine if repaired areas are sound and functioning properly.

### **Secondary Members**

Examine solid sawn or glulam diaphragms for decay, fire damage, and insect damage. Check steel cross bracing for corrosion, bowing, or buckling. Examine connections for tightness, cracks and splits, and corroded, loose, or missing fasteners. Deteriorated secondary members may indicate problems in the primary members.

### **Fasteners and Connectors**

Inspect any fastener for corrosion, tightness, and missing parts. Stressing rod hardware is the most important fastener system on a stress-laminated timber bridge.

## **8.3.5**

### **Evaluation**

---

State and Federal rating guideline systems have been developed to aid in the inspection of timber bridges. The two major rating guideline systems currently in use are the FHWA's *Recording and Coding Guide for the Structural Inventory and Appraisal of the Nation's Bridges* used for the National Bridge Inventory (NBI) component condition rating method and the *AASHTO Guide Manual for Bridge Element Inspection* used for element level condition state assessment.

### **NBI Component Condition Rating Guidelines**

Using NBI component condition rating guidelines, a one-digit code on the Federal Structure Inventory and Appraisal (SI&A) sheet indicates the condition of the superstructure. Component condition rating codes range from 9 to 0, where 9 is the best rating possible. See Topic 4.2 (Item 59) for additional details about NBI component condition rating guidelines.

Consider previous inspection data along with current inspection findings to determine the correct component condition rating.



**Element Level Condition State Assessment** In an element level condition state assessment of timber bridges, possible AASHTO National Bridge Elements (NBEs) and Bridge Management Elements (BMEs) are:

<u>NBE No.</u>	<u>Description</u>
<b>Deck/Slabs</b>	
31	Timber Deck
54	Timber Slab
<b>Superstructure</b>	
111	Timber Girder/Beam

**BME No.**

**Wearing Surfaces and Protection Systems**

520	Deck/Slab Protection System
-----	-----------------------------

The unit quantity for decks, slabs and protection systems is square feet. The total area is distributed among the four available condition states depending on the extent and severity of the deficiency. The unit quantity for the timber superstructures is feet, and the total length is distributed among the four available condition states depending on the extent and severity of the deficiency. The sum of all condition states equals the total quantity of the National Bridge Element or Bridge Management Element. Condition State 1 is the best possible rating. See the *AASHTO Guide Manual for Bridge Element Inspection* for condition state descriptions.

The following Deflect Flag is applicable in the evaluation of stress-laminated timber superstructures:

<u>Deflect Flag No.</u>	<u>Description</u>
362	Superstructure Traffic Impact (load capacity)

See the *AASHTO Guide Manual for Bridge Element Inspection* for the application of Defect Flags.

# Table of Contents

## Chapter 9

---

### Inspection and Evaluation of Concrete Superstructures

9.1	Cast-in-Place Slabs .....	9.1.1
9.1.1	Introduction.....	9.1.1
9.1.2	Design Characteristics.....	9.1.2
	General .....	9.1.2
	Primary and Secondary Members .....	9.1.2
	Steel Reinforcement .....	9.1.2
9.1.3	Overview of Common Deficiencies.....	9.1.3
9.1.4	Inspection Methods and Locations .....	9.1.4
	Methods .....	9.1.4
	Visual .....	9.1.4
	Physical .....	9.1.4
	Advanced Inspection Methods.....	9.1.4
	Locations .....	9.1.5
	Bearing Areas.....	9.1.5
	Shear Zones.....	9.1.6
	Tension Zones.....	9.1.7
	Secondary Members.....	9.1.7
	Areas Exposed to Drainage.....	9.1.8
	Areas Exposed to Traffic .....	9.1.9
	Areas Previously Repaired.....	9.1.9
	Other Areas Exposed to External Damage .....	9.1.9
	Acute Angles on Skewed Bridges.....	9.1.9
	Camber.....	9.1.9
	Thermal Effects.....	9.1.10
9.1.5	Evaluation .....	9.1.10
	NBI Component Condition Rating Guidelines.....	9.1.10
	Element Level Condition State Assessment.....	9.1.10

This page intentionally left blank

# Chapter 9

## Inspection and Evaluation of Concrete Superstructures

### Topic 9.1 Cast-in-Place Slabs

#### 9.1.1

##### Introduction

The cast-in-place slab bridge is the simplest type of reinforced concrete bridge and was a common choice for construction in the early 1900's (see Figures 9.1.1 and 9.1.2). Sometimes the terms "deck" and "slab" are used interchangeably to describe the same bridge component. However, this is incorrect. A deck is supported by a superstructure unit (beams, girders, etc.), whereas a slab is a superstructure unit supported by a substructure unit (abutments, piers, bents, etc.). A deck can be loosely defined as the top surface of the bridge, which carries the traffic and distributes loads to the superstructure. A slab serves as the superstructure and the top surface that carries the traffic. Even though slabs are defined differently than decks, many of the design characteristics, wearing surfaces, protective systems, inspection methods and locations and, evaluation, are similar. See Topic 7.2 for further details.



**Figure 9.1.1** Typical Simple Span Cast-in-Place Slab Bridge



**Figure 9.1.2** Typical Multi-Span Cast-in-Place Slab Bridge

## 9.1.2

### Design Characteristics

#### General

The slab bridge functions as a wide, shallow superstructure beam that doubles as the deck. This type of bridge generally consists of one or more simply supported spans and spans are typically less than 30 feet long. Continuous multi-span slab bridges are also in service, but not as common as simply supported slabs.

#### Primary and Secondary Members

The only primary member in a cast-in-place slab bridge is the slab itself. There are no secondary members.

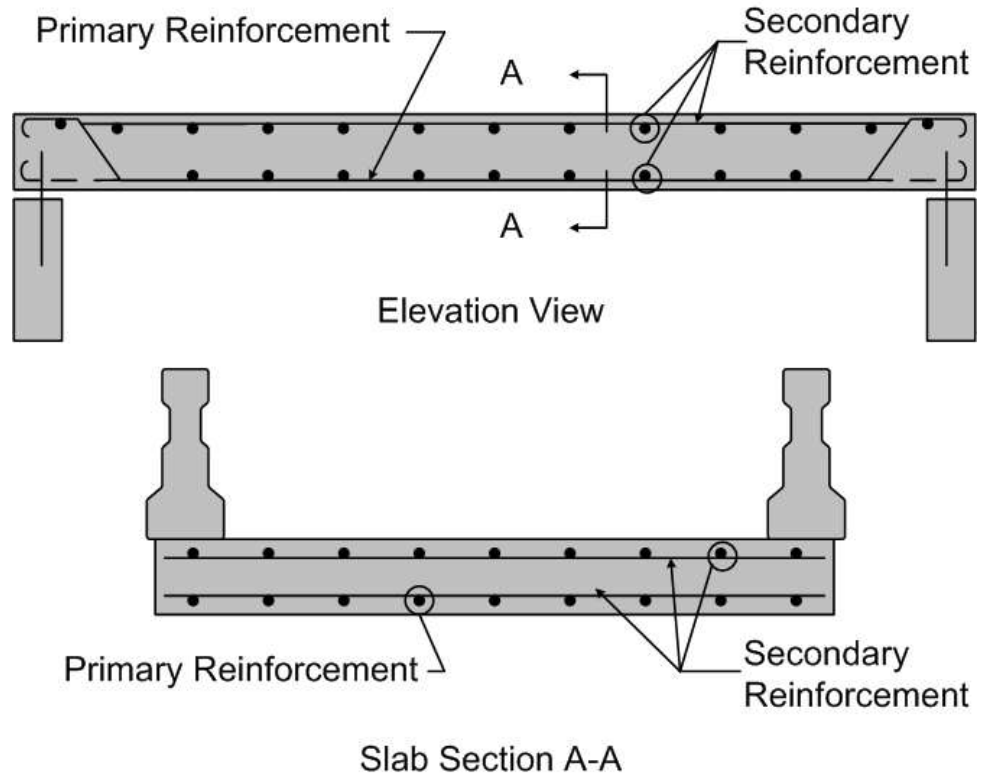
#### Steel Reinforcement

For simple spans, the slab develops only positive moment. Therefore, the primary or main tension reinforcement is located in the bottom of the slab. The reinforcement is placed longitudinally from support to support, parallel to the direction of traffic. For continuous spans, additional primary reinforcement is located longitudinally in the top of the slab over the piers to resist tension caused by negative bending moments.

Shear reinforcement is also considered to be primary reinforcement. Shear reinforcement, if required, is normally obtained by bending the tension bars at a 45 degree angle close to the slab supports. The shear reinforcement is perpendicular to diagonal tension/shear forces and therefore resists those forces.

Secondary reinforcement, known as temperature and shrinkage steel, is located transversely throughout the top and bottom of the slab. In simple span slabs, secondary reinforcement is also located longitudinally in the top of the slab. In continuous span slabs, the primary reinforcement is often placed the full structure length, negating the need for longitudinal secondary reinforcement.

Nearly all slab bridges have a grid or mat of steel reinforcement in both the top and bottom of the slab that is formed by some combination of primary and secondary reinforcement (see Figure 9.1.3).



**Figure 9.1.3** Steel Reinforcement in a Simply Supported Concrete Slab

### 9.1.3

#### Overview of Common Deficiencies

Common deficiencies that occur on cast-in-place slab bridges include:

- Cracking (structural, flexure, shear, crack size, nonstructural, crack orientation)
- Scaling
- Delamination
- Spalling
- Chloride contamination
- Freeze-thaw
- Efflorescence
- Alkali silica reactivity (ASR)
- Ettringite formation
- Honeycombs
- Pop-outs
- Wear

- Collision damage
- Abrasion
- Overload damage
- Internal steel corrosion
- Carbonation

Refer to Topic 6.2.6 for a detailed explanation of the properties of concrete, types and causes of concrete deficiencies, and the examination of concrete.

## 9.1.4

### **Inspection Methods and Locations**

Inspection methods to determine causes of concrete deficiencies are presented in detail in Topic 6.2.8.

#### **Methods**

##### **Visual**

The inspection of concrete slabs for surface cracks, spalls, wear, and other deficiencies is primarily a visual activity.

##### **Physical**

The most common physical method for inspecting concrete is to use a hammer to "sound" the concrete. However, the physical examination of the top surface of the slab with a hammer can be a tedious operation. Instead, a chain drag is used to determine delaminated areas for most cases. A chain drag is typically made of several sections of chain attached to a pipe that has a handle attached to it. The inspector drags this across a slab and makes note of the resonating sounds. A delaminated area will have a distinctive hollow "clacking" sound when tapped with a hammer or revealed with a chain drag. A hammer hitting sound concrete will result in a solid "pinging" type sound. It is not possible to use a chain drag on the bottom surface, so hammer sounding is the primary physical procedure.

##### **Advanced Inspection Methods**

Several advanced methods are available for concrete inspection.

Nondestructive methods, described in Topic 15.2.2, include:

- Acoustic wave sonic/ultrasonic velocity measurements
- Electrical methods
- Delamination detection machinery
- Ground-penetrating radar
- Electromagnetic methods
- Pulse velocity
- Flat jack testing
- Impact-echo testing
- Infrared thermography
- Laser ultrasonic testing

- Magnetic field disturbance
- Neutron probe for detection of chlorides
- Nuclear methods
- Pachometer
- Rebound and penetration methods
- Ultrasonic testing
- Smart concrete
- Carbonation

Other inspection methods or tests for material properties, described in Topic 15.2.3, include:

- Concrete permeability
- Concrete strength
- Endoscopes and videoscopes
- Moisture content
- Petrographic examination
- Reinforcing steel strength
- Chloride test
- Matrix analysis
- ASR evaluation

## **Locations**

### **Bearing Areas**

Examine bearing areas for cracking, delamination, and spalling where friction from thermal movement and high edge or bearing pressure could overstress the concrete (see Figure 9.1.4). Check the condition and operation of any bearing devices.

As detailed in Topic 7.2.6, bearing areas are located where one element "sits" on top of another element. For slabs, the bearing areas are located above the substructure supports.





**Figure 9.1.4** Bearing Area: Cast-in-Place Slab

### Shear Zones

Investigate areas near the supports for shear cracking. The presence of transverse cracks on the underside near supports or diagonal cracks on the sides of the slab indicate the onset of an overstress for shear (see Figures 9.1.5 and 9.1.6). Carefully measure cracks as they may represent lost shear capacity.



**Figure 9.1.5** Diagonal Shear Cracks Close to the Ends of a Slab Bridge



**Figure 9.1.6** Shear Zone on the Underside of a Continuous Slab Bridge Near a Pier

### **Tension Zones**

Examine tension zones for flexure cracks, which would be perpendicular to the tensile forces and vertical on the sides and transverse across the slab. The tension zones are at midspan along the bottom of the slab for both simple and continuous span bridges. Additional tension zones are located on top of the slab over the piers for continuous spans. Cracks greater than 1/16 inch wide indicate overstress due to tensile forces caused by bending stresses. Check for efflorescence from cracks and, more significant, the discoloration of the concrete caused by rust stains from the reinforcing steel. In severe cases, the reinforcing steel may become exposed due to spalling. Document the remaining cross section of reinforcing steel since section loss will decrease live load capacity (see Figure 9.1.7).

Check for deteriorated concrete near the tension zones, which could result in the debonding of the tension reinforcement. This would include delamination, spalls, and contaminated concrete (see Figure 9.1.8). Slab bridges which use hooks to develop the primary tension reinforcement are not as susceptible to debonding due to deterioration of the concrete.

### **Secondary Members**

The slab bridge has no secondary members.



**Figure 9.1.7** Inspector examining and documenting deficiencies in concrete slab



**Figure 9.1.8** Concrete Slab Tension Zone: Delamination, Efflorescence, Rust, and Stains

### **Areas Exposed to Drainage**

Inspect areas exposed to roadway drainage for deteriorated concrete. This includes the entire riding surface of the slab, particularly around scuppers or drains. Spalling or scaling may also be found along the curblines and fascias (see Figure 9.1.9).

### Areas Exposed to Traffic

For grade crossing structures, check areas exposed to traffic for damage caused by collision. Such damage will generally consist of corner spalls and may include exposed rebars. Also examine the top surface for signs of wear caused by vehicular traffic.

### Areas Previously Repaired

Examine areas that have been previously repaired. Determine if the repairs are in place, and they are functioning properly.

### Other Areas Exposed to External Damage

- Waterborne debris or ice
- Fire
- Equipment hits
- Displacement of superstructure due to floods, storm surges, etc.

### Acute Angles on Skewed Bridges

Examine skewed bridges for lateral displacement and cracking of acute corners due to point loading and insufficient reinforcement.



**Figure 9.1.9** Deteriorated Slab Fascia due to Roadway Deicing Agents

### Camber

Using a string line, check for vertical alignment (camber) changes from the as-built condition of the slab. Downward deflection usually indicates reduced capacity. Upward deflection usually indicates shrinkage.

**Thermal Effects**

These cracks are caused by non-uniform temperatures between two surfaces of the slab. Cracking will typically be transverse in the thinner regions of the slab and longitudinal near changes in cross section thickness.

**9.1.5**

**Evaluation**

State and Federal rating guideline systems have been developed to aid in the inspection of concrete bridges. The two major rating guideline systems currently in use are the FHWA's *Recording and Coding Guide for the Structural Inventory and Appraisal of the Nation's Bridges* used for the National Bridge Inventory (NBI) component condition rating method and the AASHTO *Guide Manual for Bridge Element Inspection* for element level condition state assessment.

**NBI Component Condition Rating Guidelines**

Using NBI component condition rating guidelines, a one-digit code on the Federal Structure Inventory and Appraisal (SI&A) sheet indicates the condition of the superstructure. Component condition rating codes range from 9 to 0, where 9 is the best rating possible. See Topic 4.2 (Item 59) for additional details about NBI component condition rating guidelines. For a slab bridge, these guidelines must be applied for both the deck component and the superstructure component.

Use previous inspection data along with current inspection findings to determine the correct component condition rating. For this type of structure, the deck and superstructure components may have the same rating.

**Element Level Condition State Assessment**

In an element level condition state assessment of a cast-in-place slab bridge, possible AASHTO National Bridge Elements (NBEs) and Bridge Management Elements (BMEs) are:

**NBE No.**

**Description**

**Decks/Slabs**

38

Reinforced Concrete Slab\*

\* Note that this element designation is used regardless of the type of riding surface

**BME No.**

**Description**

**Wearing Surfaces and Protection Systems**

510

Wearing Surfaces

520

Deck/Slab Protection Systems

521

Concrete Protective Coating

The unit quantity for decks, slabs, wearing surfaces, protection systems and protective coatings is square feet. The total area is distributed among the four available condition states depending on the extent and severity of the deficiency. The sum of all condition states equals the total quantity of the National Bridge

Element or Bridge Management Element. Condition State 1 is the best possible rating. See the *AASHTO Guide Manual for Bridge Element Inspection* for condition state descriptions.

The following Defect Flags are applicable in the evaluation of cast-in-place slab superstructures:

<b><u>Defect Flag No.</u></b>	<b><u>Description</u></b>
358	Concrete Cracking
359	Concrete Efflorescence
362	Superstructure Traffic Impact (load capacity)

See the *AASHTO Guide Manual for Bridge Element Inspection* for the application of Defect Flags.

This page intentionally left blank.

# Table of Contents

## Chapter 9

---

### Inspection and Evaluation of Concrete Superstructures

9.2	Cast-In-Place Tee Beam.....	9.2.1
9.2.1	Introduction.....	9.2.1
9.2.2	Design Characteristics.....	9.2.1
	General.....	9.2.1
	Primary and Secondary Members.....	9.2.3
	Steel Reinforcement.....	9.2.4
9.2.3	Overview of Common Deficiencies.....	9.2.5
9.2.4	Inspection Methods and Locations .....	9.2.6
	Methods .....	9.2.6
	Visual .....	9.2.6
	Physical .....	9.2.6
	Advanced Inspection Methods .....	9.2.6
	Locations.....	9.2.7
	Bearing Areas.....	9.2.7
	Shear Zones.....	9.2.9
	Tension Zones .....	9.2.10
	Secondary Members.....	9.2.12
	Areas Exposed to Drainage .....	9.2.12
	Areas Exposed to Traffic.....	9.2.14
	Areas Previously Repaired .....	9.2.14
	Other Areas Exposed to External Damage.....	9.2.15
	Camber .....	9.2.15
	Thermal Effects .....	9.2.15
9.2.5	Evaluation .....	9.2.15
	NBI Component Condition Rating Guidelines.....	9.2.15
	Element Level Condition State Assessment .....	9.2.16



This page intentionally left blank

# Topic 9.2 Cast-In-Place Tee Beams

## 9.2.1

### Introduction

The concrete tee beam, a predominant bridge type during the 1930's and 1940's, is generally a cast-in-place monolithic deck and stem system formed in the shape of the letter "T" (see Figure 9.2.1).

The cast-in-place tee beam is the most common type of tee beam. However, precast tee beam shapes are used by some highway agencies (see Topic 9.8).



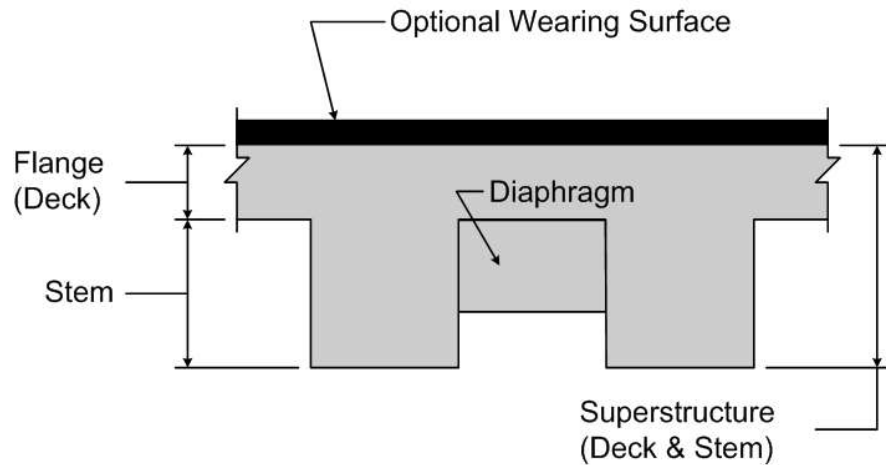
**Figure 9.2.1** Simple Span Tee Beam Bridge

## 9.2.2

### Design Characteristics

#### General

Care must be taken not to describe tee beam bridges as a composite structure. They do not meet the definition of composite, because the deck and stem are constructed of the same material. The deck portion of the beam is constructed to act integrally with the stem, providing greater stiffness and allowing increased span lengths (see Figure 9.2.2). Span lengths for tee beam bridges are typically between 30 and 50 feet.



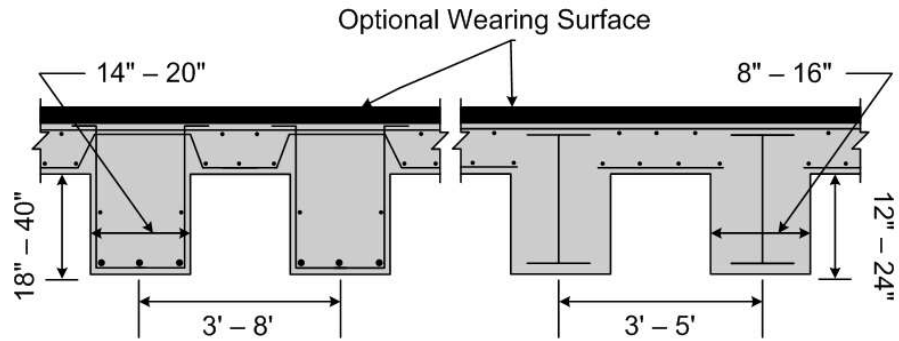
**Figure 9.2.2** Tee Beam Cross Section

Spacing of the tee beams is generally 3 to 8 feet, center-to-center of beam stems. The depth of the stems is generally 18 to 40 inches. Simple span design was most common but continuous span designs were popular in some regions (see Figure 9.2.2). A 3 or 4 inch fillet at the deck-stem intersection identifies this older form of construction.



**Figure 9.2.3** Typical Tee Beam Layout

It is important to not to mistake a concrete encased steel I-beam bridge for a tee beam bridge. A review of the structure file should eliminate this problem. If necessary, a dimensional evaluation will show the encased steel beams to be smaller in size (see Figure 9.2.4). A spall on the bottom of the stem can also indicate if there are steel reinforcement bars of a tee beam or the bottom flange of a steel I-beam.



**Figure 9.2.4** Comparison Between Tee Beam and Concrete Encased Steel I-beam



**Figure 9.2.5** Concrete Encased Steel I-beam

**Primary and Secondary Members**

The primary members of a tee beam bridge are the tee beam stem (web) and deck (flange) (see Figure 9.2.6).

Diaphragms are the only secondary members on a cast-in-place tee beam bridge. End diaphragms support the free edge of the beam flanges. Intermediate diaphragms may also be present in longer span bridges and are usually located at the half or third points along the span (see Figure 9.2.6).

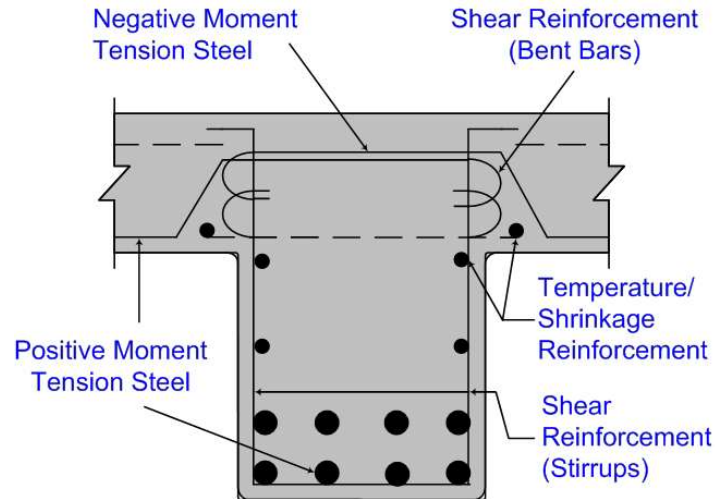


**Figure 9.2.6** Tee Beam Primary and Secondary Members

### **Steel Reinforcement**

The primary reinforcing steel consists of main tension reinforcement located longitudinally and shear reinforcement in the form of stirrups. The main tension reinforcement is located in the bottom of the beam stem to resist tensile forces caused by positive moment (see Figure 9.2.7). If the concrete tee beams are continuous, there will be additional longitudinal reinforcement close to the top surface of the deck over the piers to resist tensile forces caused by negative moment. The sides of the stem contain primary vertical shear reinforcement, called stirrups, and are located throughout the length of the stem at various spacings required by design. Stirrups are generally U-shaped bars and run transversely across the bottom of the stem (see Figure 9.2.7). The need for stirrups is greatest near the beam supports where shear stresses are the highest. Stirrup spacing is typically smaller in the stem close to the substructure supports.

The secondary (temperature and shrinkage) reinforcing steel for the stem is oriented longitudinally in the sides (see Figure 9.2.7). The primary and secondary reinforcing steel for the deck portion of the beam is the same as for a standard concrete deck (see Figure 9.2.7). Tension and shear reinforcement are transverse while temperature and shrinkage reinforcement are longitudinal.



**Figure 9.2.7** Steel Reinforcement in a Concrete Tee Beam

### 9.2.3

#### Overview of Common Deficiencies

Common deficiencies that occur on concrete tee beam bridges include:

- Cracking (structural, flexure, shear, crack size, nonstructural, crack orientation)
- Scaling
- Delamination
- Spalling
- Chloride contamination
- Freeze-thaw
- Efflorescence
- Alkali silica reactivity (ASR)
- Ettringite formation
- Honeycombs
- Pop-outs
- Wear
- Collision damage
- Abrasion
- Overload damage
- Internal steel corrosion
- Carbonation

Refer to Topic 6.2.6 for a detailed explanation of the properties of concrete, types and causes of concrete deficiencies, and the examination of concrete.

## 9.2.4

### **Inspection Methods and Locations**

Inspection methods to determine causes of concrete deficiencies are presented in detail in Topic 6.2.8.

#### **Methods**

##### **Visual**

The inspection of concrete tee beams for surface cracks, spalls, and other deficiencies is primarily a visual activity.

##### **Physical**

The physical examination of a tee beam with a hammer can be a tedious operation. In most cases, a chain drag is used to determine delaminated areas on the top flange or deck surface. The inspector drags this across a deck and makes note of the resonating sounds. A delaminated area will have a distinctive hollow "clacking" sound when tapped with a hammer or revealed with a chain drag. A hammer hitting sound concrete will result in a solid "pinging" type sound. Hammer sounding is used to examine the stem and bottom surface of the flange.

##### **Advanced Inspection Methods**

Several advanced methods are available for concrete inspection.

Nondestructive methods, described in Topic 15.2.2, include:

- Acoustic wave sonic/ultrasonic velocity measurements
- Electrical methods
- Delamination detection machinery
- Ground-penetrating radar
- Electromagnetic methods
- Pulse velocity
- Flat jack testing
- Impact-echo testing
- Infrared thermography
- Laser ultrasonic testing
- Magnetic field disturbance
- Neutron probe for detection of chlorides
- Nuclear methods
- Pachometer
- Rebound and penetration methods
- Ultrasonic testing
- Smart Concrete
- Carbonation

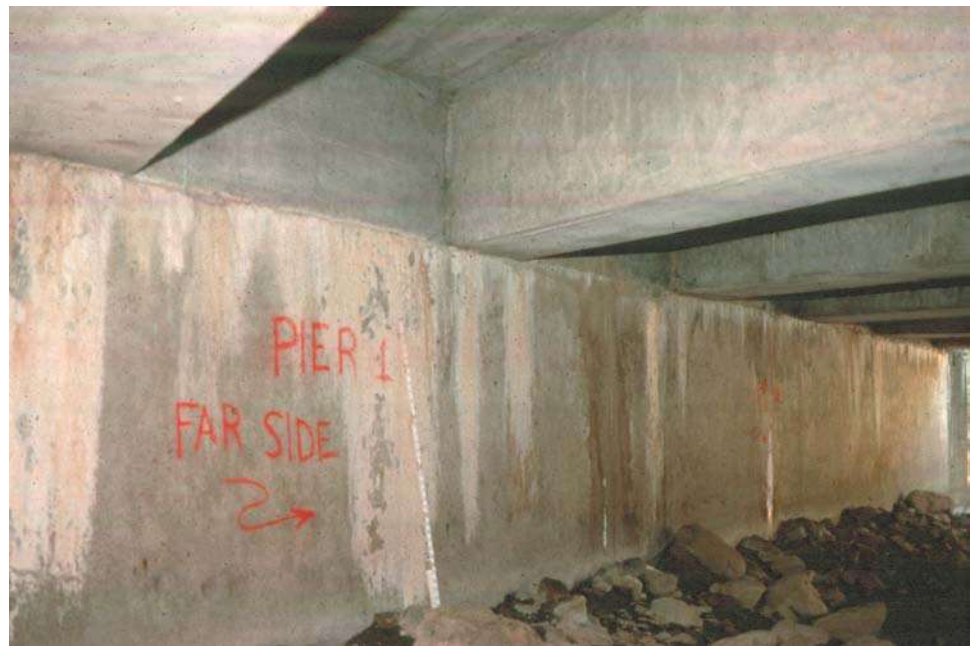
Other inspection methods or tests for material properties, described in Topic 15.2.3, include:

- Concrete permeability
- Concrete strength
- Endoscopes and videoscopes
- Moisture content
- Petrographic examination
- Reinforcing steel strength
- Chloride test
- Matrix analysis
- ASR evaluation

## Locations

### Bearing Areas

Examine bearing areas for cracking, delamination and spalling where friction from thermal movement and high bearing pressure could overstress the concrete. Check for crushing of the stem near the bearing seat. Check the condition and operation of any bearing devices (see Figures 9.2.8 through 9.2.11).



**Figure 9.2.8** Bearing Area of Typical Cast-in-Place Concrete Tee Beam Bridge





**Figure 9.2.9** Spalled Tee Beam End



**Figure 9.2.10** Deteriorated Tee Beam Bearing Area



**Figure 9.2.11** Steel Bearing Supporting a Cast-in-Place Concrete Tee Beam

### Shear Zones

Investigate the area near the supports for the presence of shear cracking. The presence of transverse cracks on the underside of the stems or diagonal cracks on the sides of the stem indicate the onset of shear failure. Carefully measure cracks, as they may represent lost shear capacity (see Figure 9.2.12).



**Figure 9.2.12** Shear Zone of Cast-in-Place Concrete Tee Beam Bridge

### Tension Zones

Examine tension zones for flexure cracks, which would be vertical on the sides and transverse across the bottom of the stem (see Figure 9.2.13). The tension zones are at the midspan along the bottom of the stem for both simple and continuous span bridges. Additional tension zones are located on the deck over the piers for continuous spans (see Figure 9.2.14). Cracks greater than 1/16 inch wide indicate overstress due to tensile forces caused by bending stresses. Check for efflorescence from cracks and discoloration of the concrete caused by rust stains from the reinforcing steel (see Figure 9.2.15). In severe cases, the reinforcing steel may become exposed due to spalling. Document the remaining cross section of reinforcing steel since section loss will decrease live load capacity (see Figure 9.2.16).

Check for deteriorated concrete near the tension zones, which could result in the debonding of the tension reinforcement. This would include delamination, spalls, and contaminated concrete (see Figures 9.2.15 and 9.2.16).

Check for efflorescence from cracks and, and more significant, the discoloration of the concrete caused by rust stains from the reinforcing steel. In severe cases, the reinforcing steel and any lap splices may become exposed due to spalling. Document the remaining cross section of reinforcing steel since section loss will decrease live load capacity.



**Figure 9.2.13** Flexure Cracks on a Tee Beam Stem



**Figure 9.2.14** Flexure Cracks in Tee Beam Flange/Deck



**Figure 9.2.15** Stem of a Cast-in-Place Concrete Tee Beam with Cracking and Efflorescence



**Figure 9.2.16** Spall on the Bottom of the Stem of a Tee Beam with Corroded Main Steel Exposed

### **Secondary Members**

Inspect diaphragms for flexure and shear cracks, as well as for typical concrete deficiencies. Deficiencies in the diaphragms may be an indication of differential settlement of the substructure or differential deflection of stems of the tee beams.

### **Areas Exposed to Drainage**

If the roadway surface is bare concrete, check for delamination, scaling, and spalls. The curb lines are most suspect. If the deck has an asphalt wearing surface, check for indications of deteriorated concrete such as reflective cracking and depressions (see Figure 9.2.17).

Check the deck soffit (underside of the bridge deck) for cracking, spalling and delaminations.

Check the exterior girder deck overhang for rotation, longitudinal cracking, settlement or misalignment of the rail. Cracking will occur parallel to the curb line (the negative moment for the deck portion).

Check around scuppers or drain holes and deck or stem fascias for deteriorated concrete (see Figure 9.2.18).

Check areas exposed to drainage for concrete spalling or cracking. This may occur at the ends of the stems where drainage has seeped through the deck joints (see Figure 9.2.19).



**Figure 9.2.17** Asphalt Covered Tee Beam Deck



**Figure 9.2.18** Deteriorated Tee Beam Stem Adjacent to Drain Hole



**Figure 9.2.19** Deteriorated Tee Beam End Due to Drainage

### **Areas Exposed to Traffic**

Check areas damaged by collision. Document the number of exposed and severed reinforcing bars with section loss as well as the spalled and delaminated concrete. The loss of concrete due to such an accident is not always serious, unless the bond between the concrete and steel reinforcement is affected (see Figure 9.2.20). If the top flange is exposed to traffic, examine for signs of wear, especially at the wheel path locations.



**Figure 9.2.20** Collision Damage to Tee Beam Bridge Over a Highway

### **Areas Previously Repaired**

Examine areas that have been previously repaired. Determine if the repairs are in place, and if they are functioning properly.

### Other Areas Exposed to External Damage

- Waterborne debris or ice
- Fire
- Equipment hits
- Displacement of superstructure due to floods, storm surges, etc.

### Camber

Using a string line, check for vertical alignment (camber) changes from the as-built condition of the tee-beam. Downward deflection usually indicates reduced capacity. Upward deflection usually indicates shrinkage.

### Thermal Effects

These cracks are caused by non-uniform temperatures between two surfaces of the tee-beam. Cracking will typically be transverse in the thinner regions of the tee-beam (such as the deck) and longitudinal near changes in cross section thickness.

## 9.2.5

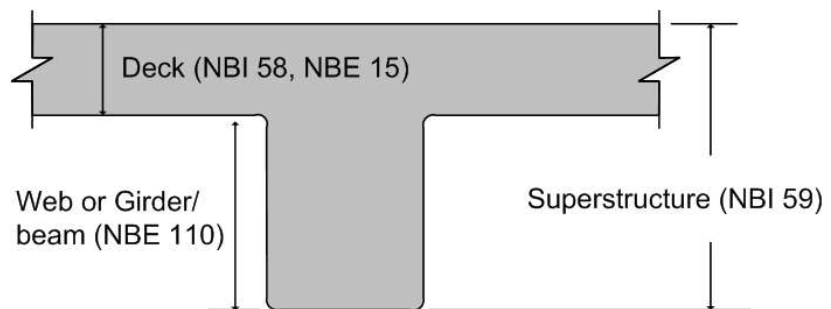
### Evaluation

State and Federal rating guideline systems have been developed to aid in the inspection of concrete bridges. The two major rating guideline systems currently in use are the FHWA's *Recording and Coding Guide for the Structural Inventory and Appraisal of the Nation's Bridges* used for the National Bridge Inventory (NBI) component condition rating method and the AASHTO *Guide Manual for Bridge Element Inspection* for element level condition state assessment.

### NBI Component Condition Rating Guidelines

Using NBI component condition rating guidelines, a one-digit code on the Federal Structure Inventory and Appraisal (SI&A) sheet indicates the condition of the superstructure. Rating codes range from 9 to 0, where 9 is the best rating possible. See Topic 4.2 (Items 58 and 59) for additional details about NBI component condition rating guidelines.

Use previous inspection data along with current inspection findings to determine the correct component condition rating. For concrete tee beams, the deck acts as the top flange and influences the superstructure NBI component condition rating (see Figure 9.2.21). When the deck component condition rating is 4 or less, the superstructure component condition rating may be reduced if the recorded deck defects reduce its ability to carry applied stresses associated with superstructure moments.



**Figure 9.2.21** Components/Elements for Evaluation



**Element Level Condition State Assessment** In an element level condition state assessment of a tee beam bridge, possible AASHTO National Bridge Elements (NBEs) and Bridge Management Elements (BMEs) are:

<u>NBE No.</u>	<u>Description</u>
<b>Decks/Slabs</b>	
15	Prestressed/Reinforced Concrete Top Flange* * Note that this element designation is used regardless of the type of riding surface.
<b>Superstructure</b>	
110	Reinforced Concrete Girder/Beam

<u>BME No.</u>	<u>Description</u>
<b>Wearing Surfaces and Protection Systems</b>	
510	Wearing Surfaces
520	Deck/Slab Protection Systems
521	Concrete Protective Coating

The unit quantity for the top flange (deck), wearing surfaces, protection systems and protective coatings is square feet. The total area is distributed among the four available condition states depending on the extent and severity of the deficiency. For the beam (NBE No. 110), the evaluation is based solely on the web for tee beams. The unit quantity for the beam is feet, and the total length is distributed among the four available condition states depending on the extent and severity of the deficiency. The sum of all condition states equals the total quantity of the National Bridge Element or Bridge Management Element. Condition State 1 is the best possible rating. See the *AASHTO Guide Manual for Bridge Element Inspection* for condition state descriptions.

The following Defect Flags are applicable in the evaluation of tee-beam superstructures:

<u>Defect Flag No.</u>	<u>Description</u>
358	Concrete Cracking
359	Concrete Efflorescence
362	Superstructure Traffic Impact (load capacity)

See the *AASHTO Guide Manual for Bridge Element Inspection* for the application of Defect Flags.

# Table of Contents

## Chapter 9

---

### Inspection and Evaluation of Concrete Superstructures

9.3	Conventionally Reinforced Concrete Two-Girder System .....	9.3.1
9.3.1	Introduction.....	9.3.1
9.3.2	Design Characteristics.....	9.3.2
	General .....	9.3.2
	Primary and Secondary Members .....	9.3.3
	Steel Reinforcement .....	9.3.3
9.3.3	Overview of Common Deficiencies.....	9.3.4
9.3.4	Inspection Methods and Locations .....	9.3.5
	Methods .....	9.3.5
	Visual.....	9.3.5
	Physical.....	9.3.5
	Advanced Inspection Methods.....	9.3.5
	Locations .....	9.3.6
	Bearing Areas.....	9.3.6
	Shear Zones.....	9.3.7
	Tension Zones.....	9.3.7
	Secondary Members.....	9.3.8
	Areas Exposed to Drainage.....	9.3.8
	Areas Exposed to Traffic .....	9.3.9
	Areas Previously Repaired.....	9.3.9
	Other Areas Exposed to External Damage .....	9.3.9
	Camber.....	9.3.9
	Thermal Effects.....	9.3.9
9.3.5	Evaluation .....	9.3.10
	NBI Component Condition Rating Guidelines.....	9.3.10
	Element Level Condition State Assessment.....	9.3.10

This page intentionally left blank

# Topic 9.3 Conventionally Reinforced Concrete Two-Girder System

## 9.3.1

### Introduction

Concrete two-girder bridges generally consist of cast-in-place monolithic decks supported by a two-girder system. Concrete girders can be used as deck girders, where the deck is cast on top of the girders (Figure 9.3.1), or as through girders, where the deck is cast between the girders (see Figure 9.3.2). Through girders are very large in appearance and actually serve as the bridge's parapets, as well as the main supporting members. Many of the concrete deck and through two-girder bridges in service today were built in the 1940's.



**Figure 9.3.1** Concrete Deck Two-Girder Bridge



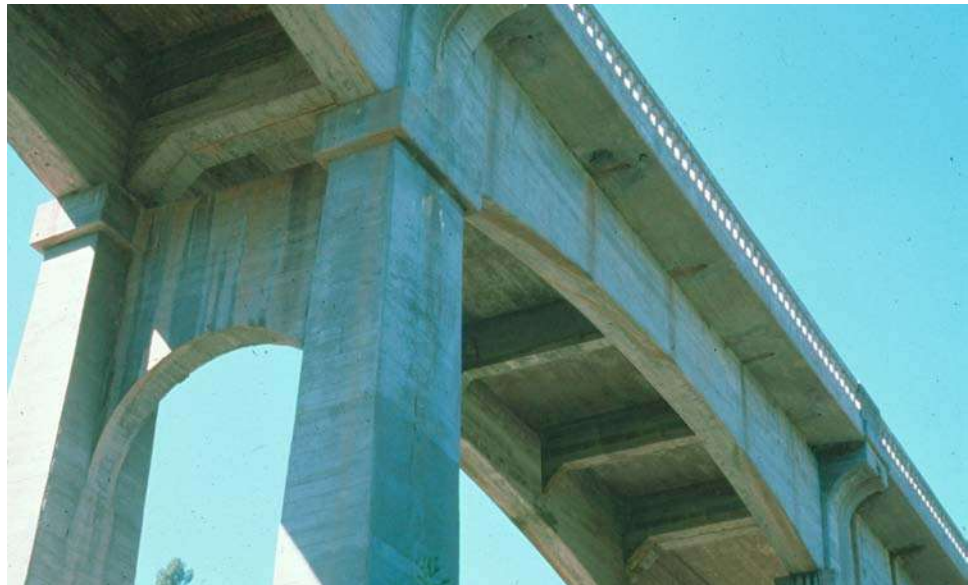
**Figure 9.3.2** Concrete Through Two-Girder Bridge

## 9.3.2

### Design Characteristics

#### General

For the purpose of inspection, the deck does not contribute to the strength of the girders and serves only to distribute traffic loads to the girders. As such, the superstructure condition rating is not affected by the condition of the deck. If floorbeams or stringers are present, they are considered part of the superstructure (see Figure 9.3.3).



**Figure 9.3.3** Concrete Deck Two-Girder, Underside View

Concrete through girders are used for spans ranging from 30 to 60 feet at locations

with a limited under-clearance (see Figure 9.3.4). They are, however, not economical for wide roadways and are usually limited to approximately 24 feet wide. Girders are usually 18 to 30 inches wide and 4 to 6 feet deep.



**Figure 9.3.4** Concrete Through Two-Girder Elevation View

Care must be taken not to describe concrete two-girder bridges as composite. They do not meet the definition of composite because the concrete girders and deck consist of the same material, even though they are rigidly connected with steel reinforcement.

In both a deck and a through two-girder structure, the live loads from the roadway surface are carried to the girders through the deck and stringers/floorbeams if present. The girders in turn carry the loads to the substructure.

#### **Primary and Secondary Members**

The primary members of a two-girder bridge are the girders, floorbeams and stringers (if present). The secondary members consist of diaphragms or struts.

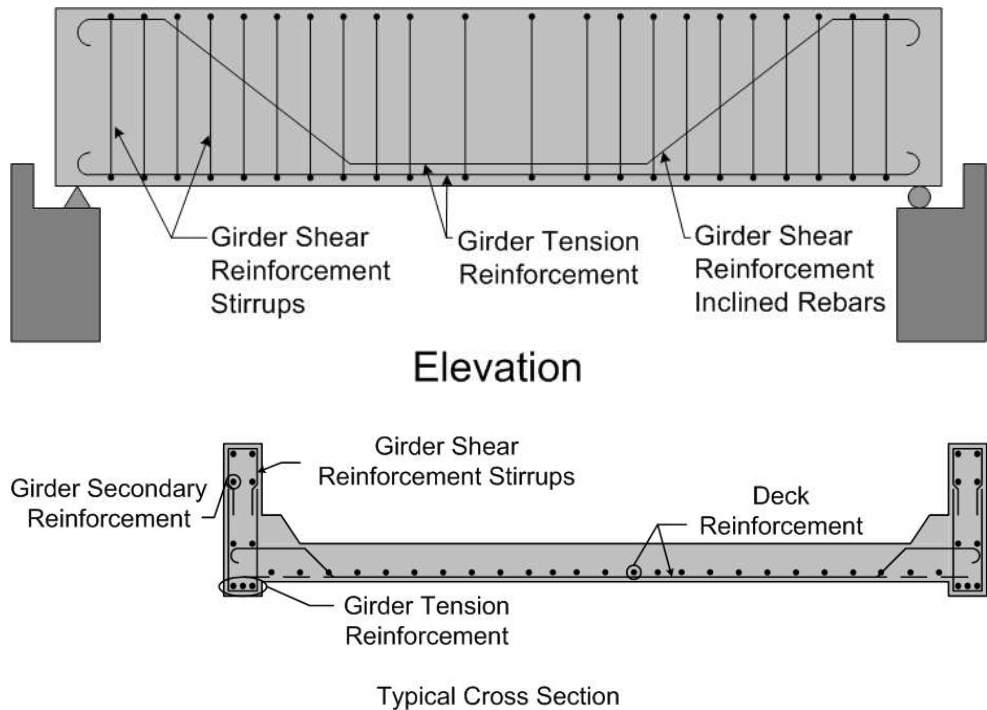
Sometimes there is confusion regarding a transverse member and whether it is a floorbeam or a diaphragm. If design drawings are available, look at the reinforcement of these members. Diaphragms will be minimally reinforced while floorbeams will have more steel reinforcement. In the absence of drawings, compare the spacing of the deck girders and the transverse members. Decks are normally reinforced to cover the shortest distance between supports. If the transverse member spacing is greater than the deck girder spacing, the deck is probably supported by the girders. For this situation, the transverse member is most likely a diaphragm. Alternatively, if the transverse member spacing is less than the deck girder spacing, the deck is probably supported by the transverse member or floorbeam. If stringers are present, the transverse members will be considered floorbeams.

#### **Steel Reinforcement**

The primary reinforcing steel consists of main longitudinal tension reinforcement and shear reinforcement in the form of stirrups or inclined rebars. The main

tension reinforcement is located in the bottom of the girder (positive moment) and on the top (negative moment). The beam also contains shear reinforcement, called stirrups that are located throughout the girder length. A single stirrup is generally two U-shaped bars that run transversely across the top, bottom and sides of the girder (see Figure 9.3.5). The need for stirrups is greatest near the beam supports where shear stresses are the highest. Shear reinforcement is also provided by bending the longitudinal bars to resist diagonal tension caused by shear.

The secondary (temperature and shrinkage) reinforcing steel is oriented longitudinally in the sides of the girders (see Figure 9.3.5). The primary and secondary reinforcing steel for the deck portion of the beam is the same as for a standard concrete deck.



**Figure 9.3.5** Steel Reinforcement in a Concrete Through Two-Girder

### 9.3.3

#### Overview of Common Deficiencies

Common deficiencies that occur on concrete two-girder bridges include:

- Cracking (structural, flexure, shear, crack size, nonstructural, crack orientation)
- Scaling
- Delamination
- Spalling
- Chloride contamination
- Freeze-thaw
- Efflorescence
- Alkali silica reactivity (ASR)

- Ettringite formation
- Honeycombs
- Pop-outs
- Wear
- Collision damage
- Abrasion
- Overload damage
- Internal steel corrosion
- Carbonation

Refer to Topic 6.2.6 for a detailed explanation of the properties of concrete, types and causes of concrete deficiencies, and the examination of concrete.

### 9.3.4

#### **Inspection Methods and Locations**

Inspection methods to determine causes of concrete deficiencies are presented in detail in Topic 6.2.8.

#### **Methods**

##### **Visual**

The inspection of concrete girders for surface cracks, spalls, and other deficiencies is primarily a visual activity.

##### **Physical**

Sounding by a hammer can be used to detect delaminated areas. A delaminated area will have a distinctive hollow "clacking" sound when tapped with a hammer. A hammer hitting sound concrete will result in a solid "pinging" type sound.

##### **Advanced Inspection Methods**

Several advanced methods are available for concrete inspection. Nondestructive methods, described in Topic 15.2.2, include:

- Acoustic wave sonic/ultrasonic velocity measurements
- Electrical methods
- Delamination detection machinery
- Ground-penetrating radar
- Electromagnetic methods
- Pulse velocity
- Flat jack testing
- Impact-echo testing
- Infrared thermography
- Laser ultrasonic testing
- Magnetic field disturbance
- Neutron probe for detection of chlorides
- Nuclear methods



- Pachometer
- Rebound and penetration methods
- Ultrasonic testing
- Smart Concrete
- Carbonation

Other inspection methods or tests for material properties, described in Topic 15.2.3, include:

- Concrete permeability
- Concrete strength
- Endoscopes and videoscopes
- Moisture content
- Petrographic examination
- Reinforcing steel strength
- Chloride test
- Matrix analysis
- ASR evaluation

## Locations

### Bearing Areas

Examine bearing areas for cracking, delamination or spalling where friction from thermal movement and high bearing pressure could overstress the concrete. Check for crushing of the girder near the bearing seat. Check the condition and operation of any bearing devices (see Figure 9.3.6).



**Figure 9.3.6** Bearing Area of a Through Two-Girder Bridge

### Shear Zones

Investigate the area near the supports for the presence of shear cracking. The presence of transverse cracks on the underside of the girders or diagonal cracks on the sides of the girders indicate the onset of shear failure. Carefully measure and document cracks, as they may indicate possible overstress due to shear.

### Tension Zones

Examine tension zones for flexure cracks, which would be vertical on the sides and transverse across the girder and possibly the deck. The tension zones are at the midspan along the bottom of the through girders and possibly the deck for both simple and continuous span bridges (see Figure 9.3.7). Additional tension zones are located along the top of the girders and possibly the deck over the piers for continuous spans. Cracks greater than 1/16 inch wide indicate overstress due to tensile forces caused by bending stresses.

Check for deteriorated concrete near the tension zones, which could result in the debonding of the tension reinforcement. This would include delamination, spalls, and contaminated concrete.

Check for efflorescence from cracks and, more significant, the discoloration of the concrete caused by rust stains from the reinforcing steel. In severe cases, the reinforcing steel and any lap splices may become exposed and debonded from the surrounding concrete due to spalling (see Figure 9.3.8). Document loss of bonding between reinforcement and concrete, section loss of concrete and remaining cross section of reinforcing steel since section loss and any debonding will decrease live load capacity.



**Figure 9.3.7** Typical Elevation View of a Through Two-Girder Bridge with Tension Zones Indicated

Check similar bearing areas, shear zones, and tension zones for floorbeams and stringers if present

### Secondary Members

Inspect diaphragms for flexural and shear cracks, as well as for typical concrete deficiencies. Deficiencies in the diaphragms may be an indication of differential settlement of the substructure or differential deflection of the concrete girders.



**Figure 9.3.8** Exposed Reinforcement in a Through Two-Girder (under hammer)

### Areas Exposed to Drainage

Inspect areas exposed to drainage. These areas will usually be at any joints or around the scuppers. Look for contamination due to deicing agents on the interior face of through girders (see Figure 9.3.9). Check around drain holes for deterioration of girder concrete.



**Figure 9.3.9** Close-up of an Interior Face of a Through Two-Girder with Heavy Scaling due to Deicing Agents

#### **Areas Exposed to Traffic**

Check areas damaged by collision. Document the number of exposed and severed reinforcing bars with section loss as well as the spalled and delaminated concrete. The loss of concrete due to such an accident is not always serious, unless the bond between the concrete and steel reinforcement is affected.

#### **Areas Previously Repaired**

Examine areas that have been previously repaired. Determine if the repairs are in place and if they are functioning properly.

#### **Other Areas Exposed to External Damage**

- Waterborne debris or ice
- Fire
- Equipment hits
- Displacement of superstructure due to floods, storm surges, etc.

#### **Camber**

Using a string line, check for vertical alignment (camber) changes from the as-built condition of the deck and girders. Downward deflection usually indicates reduced capacity. Upward deflection usually indicates shrinkage.

#### **Thermal Effects**

These cracks are caused by non-uniform temperatures between two surfaces. Cracking will typically be transverse in the thinner regions of the deck and longitudinal near changes in cross section thickness.

### 9.3.5

#### **Evaluation**

State and Federal rating guideline systems have been developed to aid in the inspection of concrete bridges. The two major rating guideline systems currently in use are the FHWA's *Recording and Coding Guide for the Structural Inventory and Appraisal of the Nation's Bridges* used for the National Bridge Inventory (NBI) component condition rating method and the AASHTO *Guide Manual for Bridge Element Inspection* for element level condition state assessment.

#### **NBI Component Condition Rating Guidelines**

Using NBI component condition rating guidelines, a one-digit code on the Federal Structure Inventory and Appraisal (SI&A) sheet indicates the condition of the superstructure. Component condition rating codes range from 9 to 0, where 9 is the best rating possible. See Topic 4.2 (Item 59) for additional details about NBI component condition rating guidelines.

Consider previous inspection data along with current inspection findings to determine the correct component condition rating.

#### **Element Level Condition State Assessment**

In an element level condition state assessment of a concrete two-girder bridge, possible AASHTO National Bridge Elements (NBEs) and Bridge Management Elements (BMEs) are:

#### **NBE No.**

#### **Description**

#### **Decks/Slabs**

12

Reinforced Concrete Deck

\* Note that this element designation is used regardless of the type of riding surface.

#### **Superstructure**

110

Concrete Open Girder/beam

116

Concrete Stringer

155

Concrete Floorbeam

#### **BME No.**

#### **Description**

#### **Wearing Surfaces and Protection Systems**

521

Concrete Protective Coating

The unit quantity for decks and protective coating is square feet. The evaluation of NBE No. 12 is based solely on the top and bottom surface condition of the deck. The total area is distributed among the four available condition states depending on the extent and severity of the deficiency. The unit quantity for the girder/beam, floorbeam or stringer is feet, and the total length is distributed among the four available condition states depending on the extent and severity of the deficiency. The sum of all condition states equals the total quantity of the National Bridge Element or Bridge Management Element. Condition State 1 is the best possible rating. See the *AASHTO Guide Manual for Bridge Element Inspection* for condition state descriptions.

CHAPTER 9: Inspection and Evaluation of Concrete Superstructures  
TOPIC 9.3: Conventionally Reinforced Concrete Two-Girder System

The following Defect Flags are applicable in the evaluation of conventionally reinforced concrete two-girder superstructures:

<b><u>Defect Flag No.</u></b>	<b><u>Description</u></b>
358	Concrete Cracking
359	Concrete Efflorescence
362	Superstructure Traffic Impact (load capacity)
366	Deck Traffic Impact (load capacity)

See the AASHTO *Guide Manual for Bridge Element Inspection* for the application of Defect Flags.

This page left intentionally blank.

# Table of Contents

## Chapter 9 Inspection and Evaluation of Concrete Superstructures

---

9.4	Concrete Channel Beams .....	9.4.1
9.4.1	Introduction.....	9.4.1
9.4.2	Design Characteristics.....	9.4.2
	General .....	9.4.2
	Primary and Secondary Members .....	9.4.2
	Steel Reinforcement .....	9.4.2
9.4.3	Overview of Common Deficiencies.....	9.4.4
9.4.4	Inspection Methods and Locations .....	9.4.4
	Methods .....	9.4.4
	Visual.....	9.4.4
	Physical.....	9.4.4
	Advanced Inspection Methods.....	9.4.5
	Locations .....	9.4.5
	Bearing Areas.....	9.4.5
	Shear Zones.....	9.4.6
	Tension Zones.....	9.4.6
	Secondary Members.....	9.4.6
	Joints .....	9.4.6
	Areas Exposed to Drainage.....	9.4.7
	Areas Exposed to Traffic .....	9.4.9
	Areas Previously Repaired.....	9.4.10
	Other Areas Exposed to External Damage .....	9.4.10
	Camber.....	9.4.10
	Thermal Effects.....	9.4.10
9.4.5	Evaluation .....	9.4.10
	NBI Condition Rating Guidelines .....	9.4.10
	Element Level Condition State Assessment.....	9.4.11



This page intentionally left blank

# Topic 9.4 Concrete Channel Beams

## 9.4.1

### Introduction

In appearance, the channel beam bridge resembles the tee beam bridge because the stems of the adjacent channel beams extend down to form a single stem (see Figures 9.4.1 and 9.4.2). The channel beam can either be pre-cast or cast-in-place.



**Figure 9.4.1** Underside View of Precast Channel Beam Bridge



**Figure 9.4.2** Underside View of a Cast-in-Place Channel Beam Bridge

## 9.4.2

### Design Characteristics

#### General

Channel beams are usually found on spans up to 50 ft.

Channel beams are generally precast and consist of a conventionally reinforced deck cast monolithically with two stems 3 to 4 feet apart (see Figure 9.4.1). Precast channel beam stems may be conventionally reinforced or may be prestressed. Stem tie bolts (see Figure 9.4.1) and shear keys (see Figure 9.4.4) are used to achieve monolithic action between precast channel beams.

Channel beams can also be cast-in-place with a curved underbeam soffit constructed over U-shaped beam forms (see Figure 9.4.2). These structures are sometimes referred as "pan bridges".



**Figure 9.4.3** General View of a Precast Channel Beam Bridge

#### Primary and Secondary Members

The primary members of channel beam bridges are the channel beams. The secondary members of channel beam bridges are the end or intermediate diaphragms.

#### Steel Reinforcement

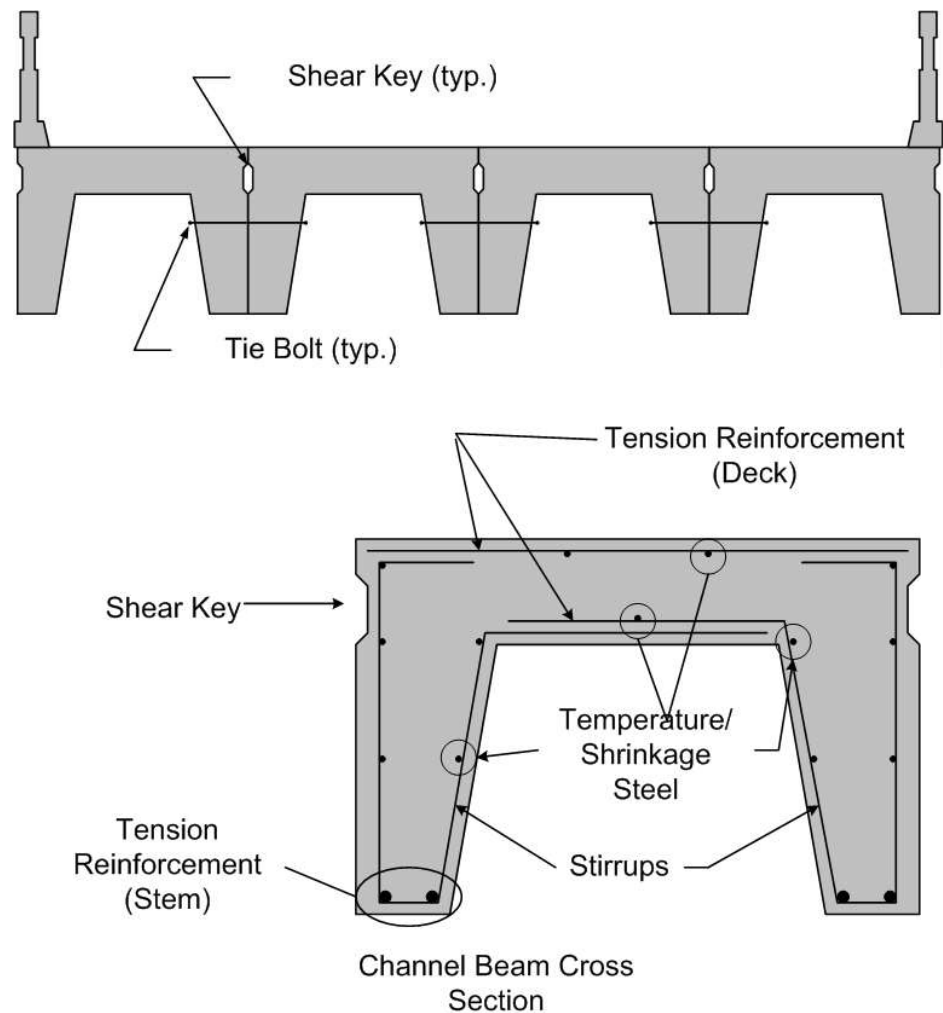
Reinforcement cover for older channel beam bridges is often less than today's cover requirements. Air entrained concrete was not specified in cast-in-place channel beams fabricated in the 1940's and early 1950's, and concrete was often poorly consolidated.

The primary reinforcing steel consists of stem tension reinforcement and shear reinforcement or stirrups. The tension reinforcement is located in the bottom of the channel stem and oriented longitudinally. The tension steel reinforcement in current channel beams consists of either mild reinforcing bars or prestressing

strands. The sides of the stems are reinforced with stirrups. The stirrups are located vertically in the sides of the channel stems at various spacings throughout the length and closer near the beam supports. The need for stirrups is greatest near the beam supports where the shear stresses are the highest.

The primary reinforcing steel for the deck portion of the beam is located in the bottom of the deck and is placed transversely, or perpendicular to the channel stems (see Figure 9.4.4).

The secondary (temperature and shrinkage) reinforcing steel is oriented longitudinally in the sides of deep channel stems and longitudinally in the deck. The primary and secondary reinforcing steel for the deck portion of the beam is the same as for a standard concrete deck (see Figure 9.4.4).



**NOTE: Tension reinforcement in stem may consist of conventional or prestressing reinforcement**

**Figure 9.4.4** Cross Section of a Typical Channel Beam

### 9.4.3

---

#### Overview of Common Deficiencies

Common deficiencies that occur on concrete channel beam bridges include:

- Cracking (structural, flexure, shear, crack size, nonstructural, crack orientation)
- Scaling
- Delamination
- Spalling
- Chloride contamination
- Freeze-thaw
- Efflorescence
- Alkali silica reactivity (ASR)
- Ettringite formation
- Honeycombs
- Pop-outs
- Wear
- Collision damage
- Abrasion
- Overload damage
- Internal steel corrosion
- Loss of prestress
- Carbonation
- Independent beam action

Refer to Topic 6.2.6 for a detailed explanation of the properties of concrete, types and causes of concrete deficiencies, and the examination of concrete.

### 9.4.4

---

#### Inspection Methods and Locations

Inspection methods to determine causes of concrete deficiencies are presented in detail in Topic 6.2.8.

##### Methods

##### Visual

The inspection of concrete channel beams for surface cracks, spalls, and other deficiencies is primarily a visual activity.

##### Physical

Sounding by hammer can be used to detect delaminated areas. A delaminated area will have a distinctive hollow "clacking" sound when tapped with a hammer or revealed with a chain drag. A hammer hitting sound concrete will result in a solid "pinging" type sound. In most cases, a chain drag is used to check the top surface of a concrete deck. Hammers are used to sound the bottom of the deck and the stems and verify the integrity and tightness of the tie bolts.

Since prestressed beams are designed to maintain all concrete in compression, cracks are indications of serious problems. Carefully measure any crack in a

prestressed channel beam with an optical crack gauge or crack comparator card and document the results.

### **Advanced Inspection Methods**

Several advanced methods are available for concrete inspection. Nondestructive methods, described in Topic 15.2.2, include:

- Acoustic wave sonic/ultrasonic velocity measurements
- Electrical methods
- Delamination detection machinery
- Ground-penetrating radar
- Electromagnetic methods
- Pulse velocity
- Flat jack testing
- Impact-echo testing
- Infrared thermography
- Laser ultrasonic testing
- Magnetic field disturbance
- Neutron probe for detection of chlorides
- Nuclear methods
- Pachometer
- Rebound and penetration methods
- Ultrasonic testing
- Smart Concrete
- Carbonation

Other inspection methods or tests for material properties, described in Topic 15.2.3, include:

- Concrete permeability
- Concrete strength
- Endoscopes and videoscopes
- Moisture content
- Petrographic examination
- Reinforcing steel strength
- Chloride test
- Matrix analysis
- ASR evaluation

### **Locations**

#### **Bearing Areas**

Inspect bearing areas for cracking, delamination or spalling where friction from thermal movement and high bearing pressure could overstress the concrete. Check for crushing of the stem near the bearing seat. Check the condition and operation of any bearing devices.

### **Shear Zones**

Inspect the area near the supports for the presence of shear cracking. The presence of transverse cracks on the underside of the stem or diagonal cracks on the sides of the stems indicate the onset of shear failure. Carefully measure and document cracks as they may indicate possible overstress due to shear.

### **Tension Zones**

Examine superstructure tension zones for flexure cracks, which would be vertical on the sides and transverse across the bottom of the stem. The tension zones are at the midspan along the bottom of the stem for both simple and continuous span bridges. Additional tension zones are located on the deck over the piers for continuous spans.

Flexure cracks caused by tension due to positive bending moment in the deck will be found on the underside in a longitudinal direction.

Check for deteriorated concrete near the tension zones, which could result in the debonding of the tension reinforcement. This would include delamination, spalls, and contaminated concrete. These could occur on both the concrete stems and the deck.

Check for efflorescence from cracks and, more significant, discoloration of the concrete caused by rust stains from the reinforcing steel. In severe cases, the reinforcing steel may become exposed and debonded from the surrounding concrete due to spalling. Document loss of bonding between reinforcement and concrete, section loss of concrete and remaining cross section of reinforcing steel since section loss and any debonding will decrease live load capacity. Check for evidence of sagging or camber loss.

### **Secondary Members**

Inspect diaphragms (see figures 9.4.5 and 9.4.9) for flexural and shear cracks as well as for typical concrete deficiencies. Deficiencies in the diaphragms may be an indication of differential settlement of the substructure or differential deflection of the concrete channel beams where only one beam is taking the load, not two or three as designed.

### **Joints**

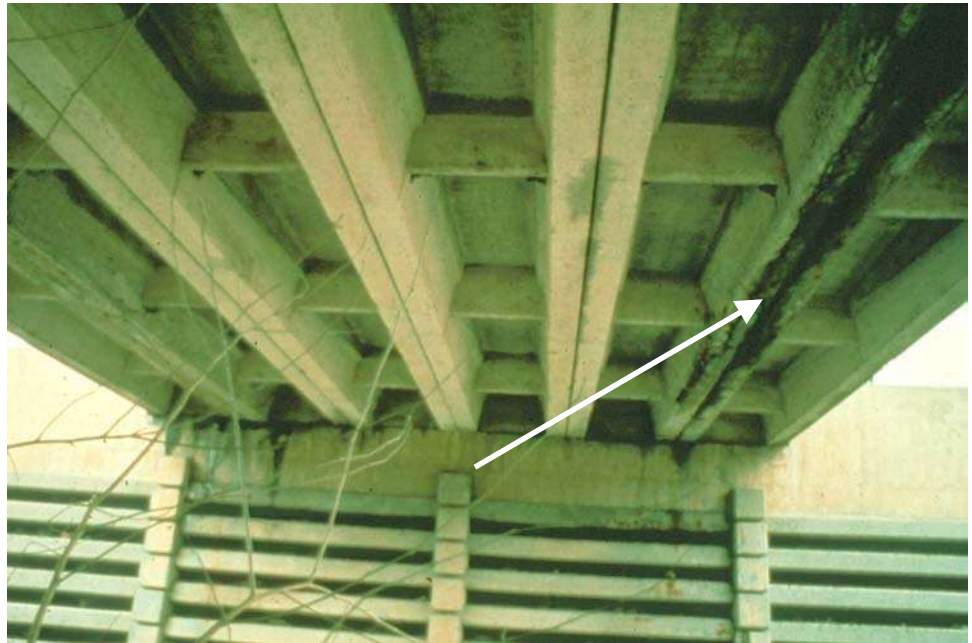
Inspect joints between adjacent beams for crushing and movement of the shear keys. The presence of open or loose joints needs to be documented. Areas where the type of construction required closure joints or segments to be poured in place will need close attention. These areas sometimes are regions of tendon anchorages and couplers (if prestressed). The stress concentrations in these areas are very much different than a section away from the anchorages where a distributed stress pattern exists. Additionally, the effects of creep and tendon relaxation are somewhat higher in these regions.

### Areas Exposed to Drainage

Inspect the seam or joint between adjacent precast beams for leakage. Leakage generally indicates a broken shear key between the channel beams (see Figure 9.4.5). If signs of leakage are present between beams, closely observe the shear keys for differential channel beam deflection under live load (see Figure 9.4.6). Also, check beam ends for concrete deterioration due to leaking joints.

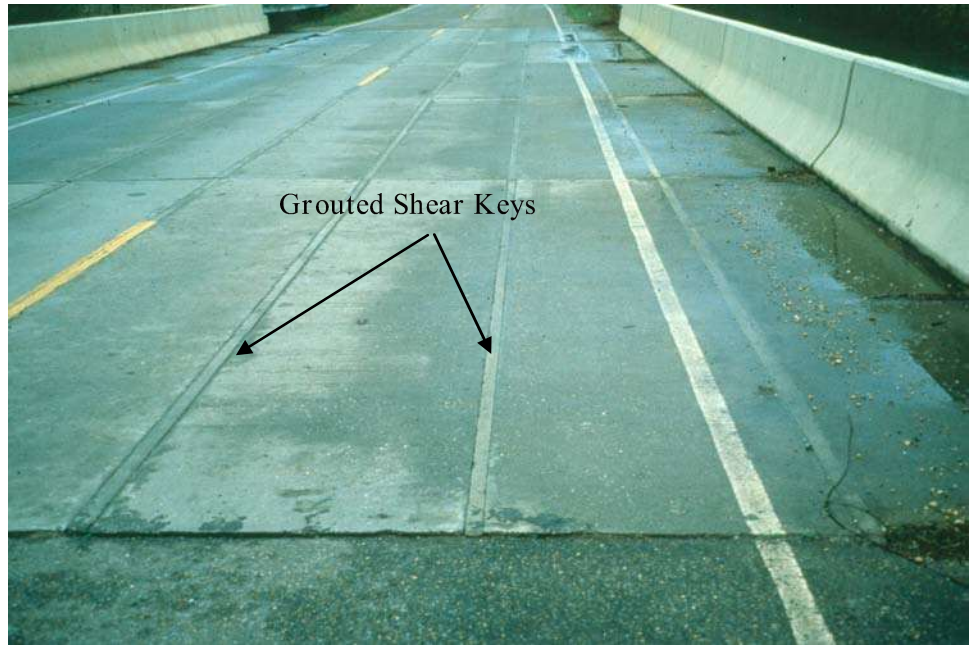
Examine areas exposed to drainage. Look for spalls and contamination at the ends and edges of the channel beams, scuppers, drain holes, and the curb line.

Check the stem tie-bolts for tightness and corrosion (see Figures 9.4.7 and 9.4.8). Do not confuse signs of corrosion with the epoxy used for the bolt.



**Figure 9.4.5** Joint Leakage Between Channel Beams





**Figure 9.4.6** Top of Deck View of Precast Channel Beam Bridge



**Figure 9.4.7** Stem Tie-Bolts



**Figure 9.4.8** Close-up of Stem Tie-Bolt (Epoxy Resin)



**Figure 9.4.9** Close-up of Intermediate Diaphragm

#### **Areas Exposed to Traffic**

Check areas damaged by collision. Document the number of exposed and severed reinforcing bars or prestressing strands with section loss, as well as the spalled and delaminated concrete. The loss of concrete due to such an accident is not always serious, unless the bond between the concrete and steel reinforcement is affected.

### Areas Previously Repaired

Examine areas that have been previously repaired. Determine if the repairs are in place, and if they are functioning properly.

### Other Areas Exposed to External Damage

- Waterborne debris or ice
- Fire
- Equipment hits
- Displacement of superstructure due to floods, storm surges, etc.

### Camber

Using a string line, check for vertical alignment (camber) changes from the as-built condition of the channel beams. Downward deflection usually indicates reduced capacity or loss of prestress (if prestressed). Upward deflection usually indicates shrinkage or excessive initial prestressing force (if prestressed).

### Thermal Effects

These cracks are caused by non-uniform temperatures between two surfaces of the channel beam. Cracking will typically be transverse in the thinner regions of the channel beam and longitudinal near changes in cross section thickness.

## 9.4.5

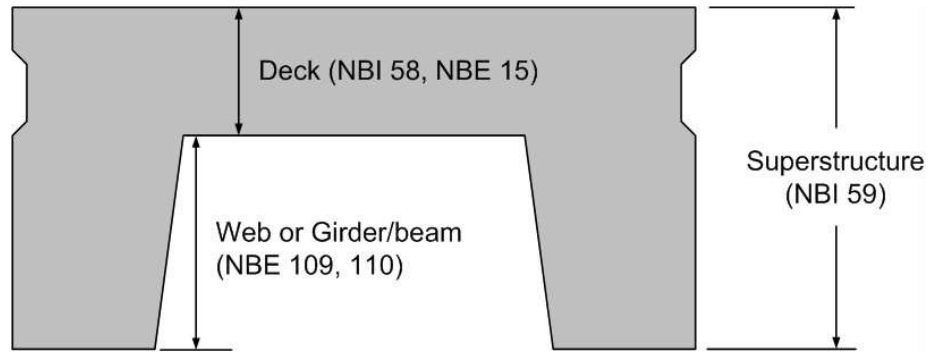
### Evaluation

State and Federal rating guideline systems have been developed to aid in the inspection of concrete bridges. The two major rating guideline systems currently in use are the FHWA's *Recording and Coding Guide for the Structural Inventory and Appraisal of the Nation's Bridges* used for the National Bridge Inventory (NBI) component condition rating method and the AASHTO *Guide Manual for Bridge Element Inspection* for element level condition state assessment.

### NBI Component Condition Rating Guidelines

Using NBI component condition rating guidelines, a one-digit code on the Federal Structure Inventory and Appraisal (SI&A) sheet indicates the condition of the superstructure. Component condition rating codes range from 9 to 0, where 9 is the best rating possible. See Topic 4.2 (Items 58 and 59) for additional details about NBI component condition rating guidelines.

Consider previous inspection data along with current inspection findings to determine the correct component condition rating. For concrete channel beams, the deck condition influences the superstructure component rating (see figure 9.4.10). When the deck component condition rating is 4 or less, the superstructure component condition rating may be reduced if the recorded deck deficiencies reduce its ability to carry applied stresses associated with superstructure moments.



**Figure 9.4.10** Components/Elements for Evaluation

**Element Level Condition State Assessment** In an element level condition state assessment of a concrete channel beam bridge, possible AASHTO National Bridge Elements (NBEs) and Bridge Management Elements (BMEs) are:

<u>NBE No.</u>	<u>Description</u>
<b>Decks/Slabs</b>	
15	Prestressed/Reinforced Concrete Top Flange* * Note that this element designation is used regardless of the type of riding surface.
<b>Superstructure</b>	
109	Prestressed Concrete Girder/Beam
110	Reinforced Concrete Girder/Beam
<u>BME No.</u>	<u>Description</u>
<b>Wearing Surfaces and Protection Systems</b>	
510	Wearing Surfaces
520	Deck/Slab Protection Systems
521	Concrete Protective Coating

The unit quantity for the top flange, wearing surfaces, protection systems and protective coating is square feet. The total area is distributed among the four available condition states depending on the extent and severity of the deficiency (see Figure 9.4.10). The unit quantity for the girder is feet, and the total length is distributed among the four available condition states depending on the extent and severity of the deficiency. The sum of all condition states equals the total quantity of the National Bridge Element or Bridge Management Element. Condition State 1 is the best possible rating. See the AASHTO *Guide Manual for Bridge Element Inspection* for condition state descriptions.

The following Defect Flags are applicable in the evaluation of channel beam superstructures:

<b><u>Defect Flag No.</u></b>	<b><u>Description</u></b>
358	Concrete Cracking
359	Concrete Efflorescence
362	Superstructure Traffic Impact (load capacity)

See the AASHTO *Guide Manual for Bridge Element Inspection* for the application of Defect Flags.

# Table of Contents

## Chapter 9

---

### Inspection and Evaluation of Concrete Superstructures

9.5	Concrete Arches.....	9.5.1
9.5.1	Introduction.....	9.5.1
9.5.2	Design Characteristics.....	9.5.1
	General .....	9.5.1
	Open Spandrel Arch.....	9.5.1
	Closed Spandrel Arch .....	9.5.2
	Through Arch.....	9.5.2
	Precast Arch.....	9.5.3
	Primary and Secondary Members .....	9.5.5
	Open Spandrel Arch.....	9.5.5
	Closed Spandrel Arch .....	9.5.6
	Steel Reinforcement .....	9.5.7
	Open Spandrel Arch.....	9.5.7
	Closed Spandrel Arch .....	9.5.8
	Other Reinforcement.....	9.5.9
9.5.3	Overview of Common Deficiencies.....	9.5.9
9.5.4	Inspection Methods and Locations .....	9.5.10
	Methods .....	9.5.10
	Visual.....	9.5.10
	Physical.....	9.5.10
	Advanced Inspection Methods.....	9.5.10
	Locations .....	9.5.11
	Bearing Areas.....	9.5.11
	Shear Zones.....	9.5.13
	Tension Zones.....	9.5.13
	Compression Zones.....	9.5.14
	Movement of Spandrel Wall.....	9.5.15
	Secondary Members.....	9.5.15
	Areas Exposed to Drainage.....	9.5.15
	Areas Exposed to Traffic .....	9.5.16
	Areas Previously Repaired.....	9.5.16
	Other Areas Exposed to External Damage .....	9.5.16
9.5.5	Evaluation .....	9.5.16
	NBI Condition Rating Guidelines .....	9.5.16
	Element Level Condition State Assessment.....	9.5.16

This page intentionally left blank.

# Topic 9.5 Concrete Arches

## 9.5.1

### Introduction

A true arch has an elliptical shape and functions in a state of pure axial compression. It can be thought of as a long curved column. This makes the true arch an ideal form for the use of concrete due to its high compressive capacity. Unfortunately, the true arch form is often compromised to adjust for a specific bridge site. Because of this compromise, modern concrete arch bridges resist a load combination of bending moments, and shear in addition to axial compression.

## 9.5.2

### Design Characteristics

The basic design concept in arch construction utilizes a "building block" approach. Arch elements, although connected, are stacked or "bearing" on top of one another. The elements at the bottom of the pile receive the largest compressive loads due to the weight of the elements above. Arch spans are always considered "simple span" designs because of the basic arch function.

### General

#### Open Spandrel Arch

The open spandrel concrete arch is considered a deck arch since the roadway is above the arches. The area between the arches and the roadway is called the spandrel.

Open spandrel concrete arches receive traffic loads through spandrel bents that support a deck or tee beam floor system (see Figure 9.5.1). This type of arch is generally for 200 feet and longer spans.



**Figure 9.5.1** Open Spandrel Arch Bridge



### **Closed Spandrel Arch**

Closed spandrel arches are deck arches since the roadway is above the arch. The spandrel area (i.e., the area between the arch and the roadway) is occupied by fill retained by vertical walls. The arch member is called a ring or barrel and is continuous between spandrel walls.

Closed spandrel arches receive traffic loads through the fill material which is contained by spandrel walls (see Figure 9.5.2). This type of arch is efficient in short span applications.



**Figure 9.5.2** Multi-span Closed Spandrel Arch Bridge

A closed spandrel arch with no fill material has a hollow vault between the spandrel walls. This type of arch has a floor system similar to the open spandrel arch and is inspected accordingly.

### **Through Arch**

A concrete through arch is constructed having the crown of the arch above the deck and the arch foundations below the deck. Hangers or cables suspend the deck from the arch. Concrete through arches are very rare (see Figure 9.5.3). These types of arches are sometimes referred to as "Rainbow Arches".



**Figure 9.5.3** Concrete Through Arch Bridge

### **Precast Arch**

Precast concrete arches are gaining popularity and can be integral or segmental. The integral arches typically have an elliptical barrel with vertical integral sides (see Figure 9.5.4). Segmental arches are oval or elliptical and can have several hinges along the arch (see Figure 9.5.5). The hinges allow for rotation and eliminate the moment at the hinge location. Both integral and segmental precast arch sections are bolted or post-tensioned together perpendicular to the arch.



**Figure 9.5.4** Precast Concrete Arch with Integral Vertical Legs



**Figure 9.5.5** Precast Segmental Concrete Arch

Large segmental precast arches that are post-tensioned have the ability to span great distances. This type of arch is constructed from the arch foundations to the crown using segmental hollow sections. The segmental sections are post-tensioned together along the arch through post-tensioning ducts placed around the perimeter of the segmental section. For this type of design, the deck and supporting members bear on the top or crown of the arch (see Figure 9.5.6).

High quality control can be obtained for precast arches. Sections are precast in a casting yard which allows manufacturers to properly monitor the concrete placement and curing. Reinforcement clearances and placement is also better controlled in a casting yard. Precast sections are typically tested prior to gaining acceptance for use. This ensures that the product can withstand the required loads that are applied.



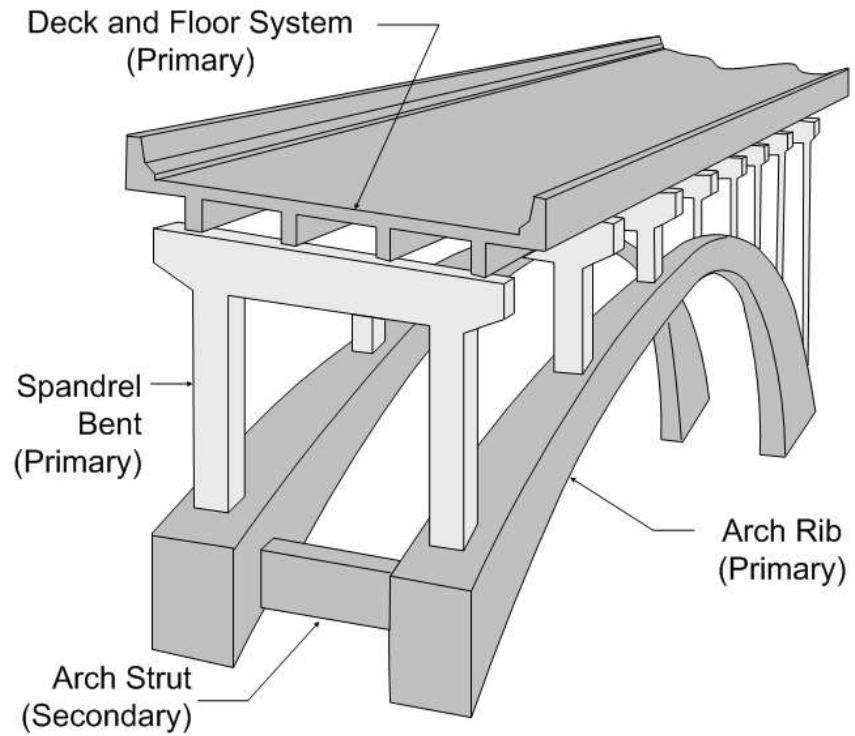
**Figure 9.5.6** Precast Post-tensioned Concrete Arch without Spandrel Columns

### **Primary and Secondary Members**      **Open Spandrel Arch**

The reinforced concrete open spandrel arch consists of one or more arch ribs. The arch members are the primary load-carrying elements of the superstructure. The arch and the following members supported by the arch are also considered primary superstructure elements:

- Spandrel bents - support floor system
- Spandrel bent cap - transverse beam member of the spandrel bent
- Spandrel columns - vertical members of the spandrel bent which support the spandrel bent cap
- Spandrel beams - fascia beams of the floor system
- Floor system - a deck or tee beam arrangement supported by the spandrel bent caps and the substructure elements

The secondary members of an open spandrel arch bridge are the arch struts, which are transverse beam elements connecting the arch ribs. Arch struts provide stability against lateral forces and reduce the unsupported compression length between supports (see Figure 9.5.7).

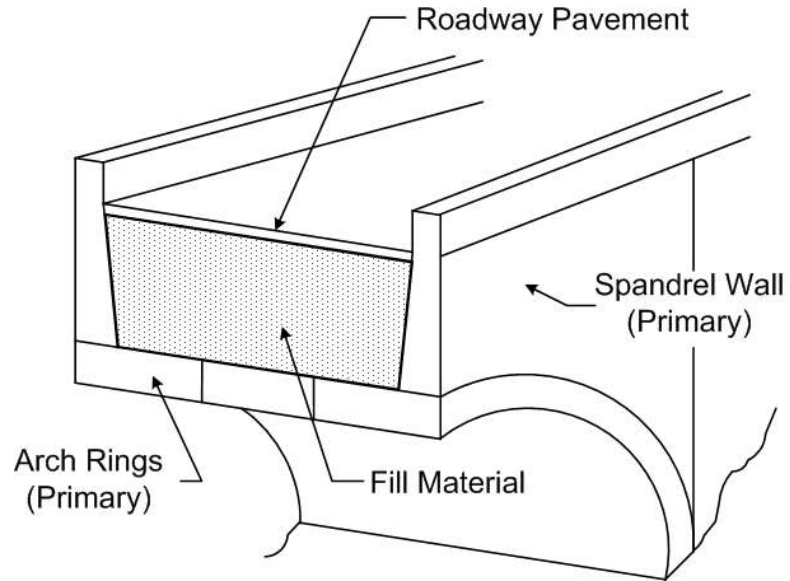


**Figure 9.5.7** Primary and Secondary Members of an Open Spandrel Arch

#### **Closed Spandrel Arch**

For a closed spandrel arch, the primary members are the arch rings and spandrel walls. The arch rings support fill material, roadway, and traffic, while the spandrel walls retain fill material and support the bridge parapets.

The arch and members supported by the arch are superstructure elements. The arch itself is the primary load-carrying element of the superstructure (see Figure 9.5.8).



**Figure 9.5.8** Primary Members of a Closed Spandrel Arch

## Steel Reinforcement

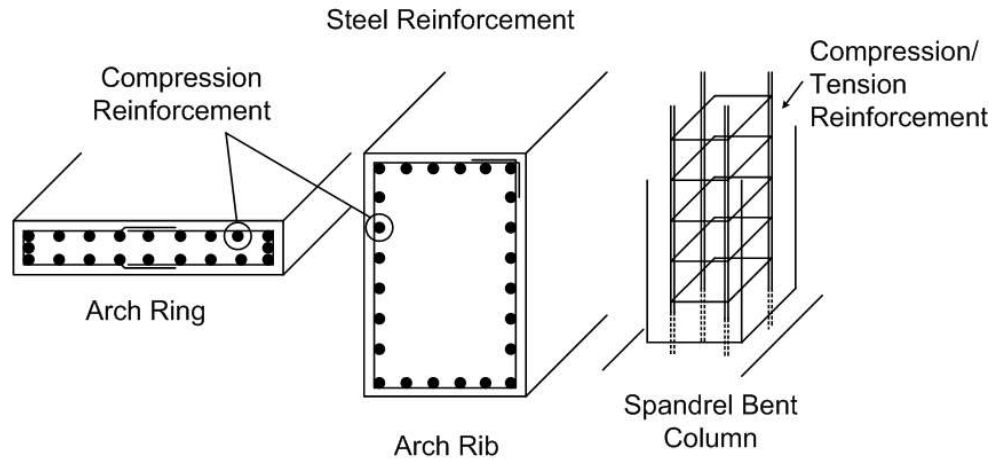
For the proper inspection and evaluation of concrete arch bridges, the inspector must be familiar with the location and purpose of steel reinforcement.

### Open Spandrel Arch

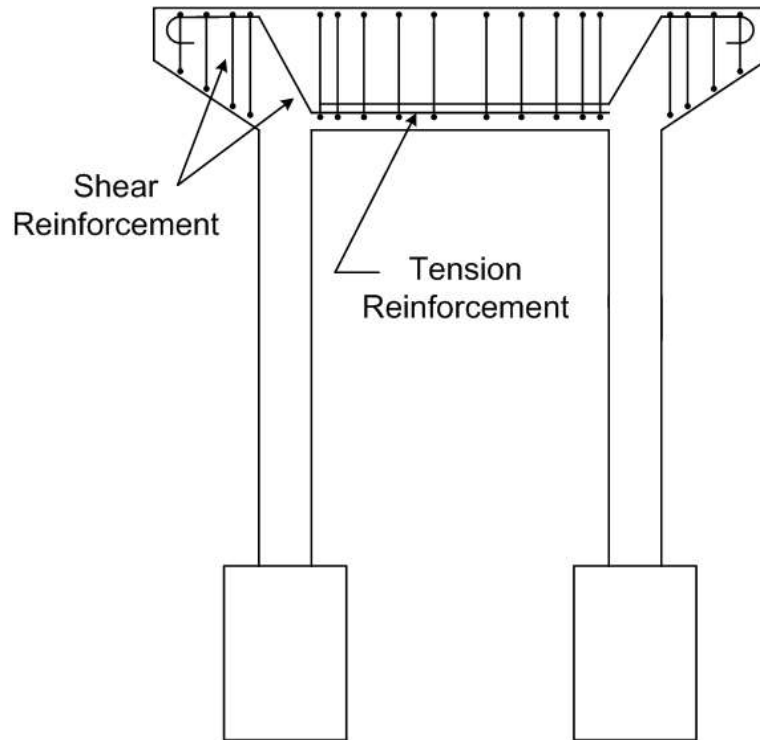
The primary reinforcing steel in an open spandrel arch follows the shape of the arch from support to support. Since the arch is a compression member, reinforcement is similar to column reinforcement. The surfaces of the arch rib are reinforced with equal amounts of longitudinal steel held in place with lateral ties. This longitudinal or column reinforcement can act as compression reinforcement when the arch must resist moment due to axial load eccentricity or lateral loads. Spandrel columns are also compression members and are reinforced similar to the arch rib (see Figure 9.5.9).

In spandrel bent caps, the primary reinforcement is tension and shear steel. This is provided using "Z" shaped bars and stirrups since the cap behaves like a fixed end beam (see Figure 9.5.10).

The floor system is designed and reinforced similar to other concrete beams (e.g. tee beams).



**Figure 9.5.9** Open Spandrel Arch and Spandrel Bent Column Reinforcement



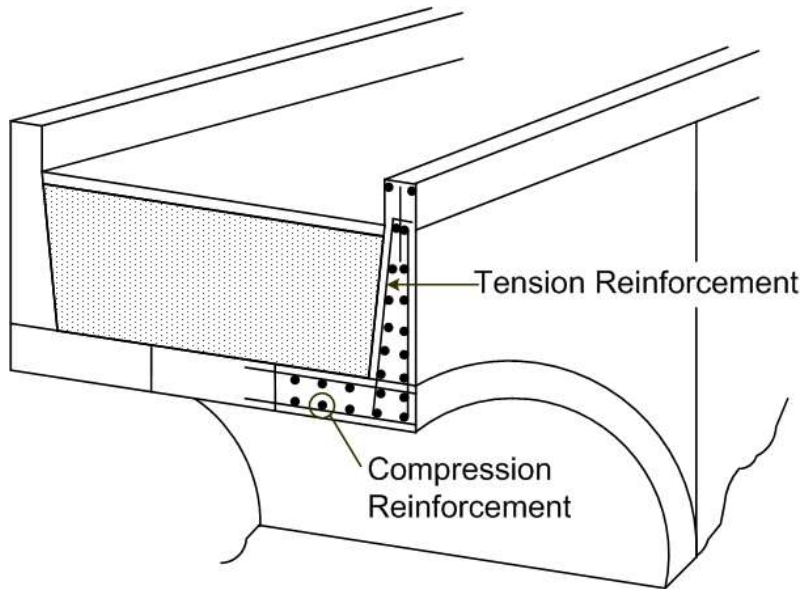
**Figure 9.5.10** Spandrel Bent Cap Reinforcement

Note that tension reinforcement in spandrel bent columns and bent caps resist tensile forces caused by bending moments in Figures 9.5.9 and 9.5.10.

### Closed Spandrel Arch

The primary reinforcing steel in the arch ring follows the shape of the arch from support to support and consists of a mat of reinforcing steel on both the top and bottom surfaces of the arch. The inspector will be unable to inspect the top surface of the arch due to the backfill.

The spandrel walls are designed to retain the backfill material. The primary tension steel for the wall is usually at the back, or unexposed, face of the wall, hidden from view and resists tension caused by lateral earth pressure bending. Lateral ties or connections between the roadway slab and the spandrel walls are sometimes used to resist this tension. The front, or outside, face of the wall is reinforced in both directions with temperature and shrinkage steel (see Figure 9.5.11).



**Figure 9.5.11** Reinforcement in a Closed Spandrel Arch

### Other Reinforcement

Temperature and shrinkage reinforcement is used in the spandrel bent caps and spandrel walls.

Lateral ties are used to support compressive reinforcement in the arch rings and arch ribs.

## 9.5.3

### Overview of Common Deficiencies

Common deficiencies that occur on concrete arches include:

- Cracking (structural, flexure, shear, crack size, nonstructural, crack orientation)
- Scaling
- Delamination
- Spalling
- Chloride contamination
- Freeze-thaw
- Efflorescence
- Alkali silica reactivity (ASR)
- Ettringite formation



- Honeycombs
- Pop-outs
- Wear
- Collision damage
- Abrasion
- Overload damage
- Internal steel corrosion
- Loss of prestress
- Carbonation

Refer to Topic 6.2.6 for a detailed presentation of the properties of concrete, types and causes of concrete deficiencies, and the examination of concrete.

## 9.5.4

### **Inspection Methods and Locations**

Inspection methods to determine causes of concrete the deficiencies are presented in detail in Topic 6.2.8.

#### **Methods**

##### **Visual**

The inspection of concrete arches for surface cracks, spalls, and other deficiencies is primarily a visual activity.

##### **Physical**

Sounding by hammer can be used to detect areas of delamination. A delaminated area will have a distinctive hollow "clacking" sound when tapped with a hammer. A hammer hitting sound concrete will result in a solid "pinging" type sound.

##### **Advanced Inspection Methods**

Several advanced methods are available for concrete inspection. Nondestructive methods, described in Topic 15.2.2, include:

- Acoustic wave sonic/ultrasonic velocity measurements
- Electrical methods
- Delamination detection machinery
- Ground-penetrating radar
- Electromagnetic methods
- Pulse velocity
- Flat jack testing
- Impact-echo testing
- Infrared thermography
- Laser ultrasonic testing
- Magnetic field disturbance
- Neutron probe for detection of chlorides
- Nuclear methods
- Pachometer

- Rebound and penetration methods
- Ultrasonic testing
- Smart Concrete
- Carbonation

Other inspection methods or tests for material properties, described in Topic 15.2.3, include:

- Carbonation
- Concrete permeability
- Concrete strength
- Endoscopes and videoscopes
- Moisture content
- Petrographic examination
- Reinforcing steel strength
- Chloride test
- Matrix analysis
- ASR evaluation

## Locations

### Bearing Areas

The arch/skewback interface has the greatest bearing load magnitude (see Figure 9.5.12). Inspect for loss of cross section of the reinforcement bars at the spalls. Examine the arch for longitudinal cracks. These may indicate an overstress condition.

The arch/spandrel column interface has the second greatest bearing load magnitude. Examine for reinforcement cross-section loss at the spalls. Check for horizontal cracks in the columns within several feet from the arch. These indicate excessive bending in the column, which is caused by overloads and differential arch rib deflection.

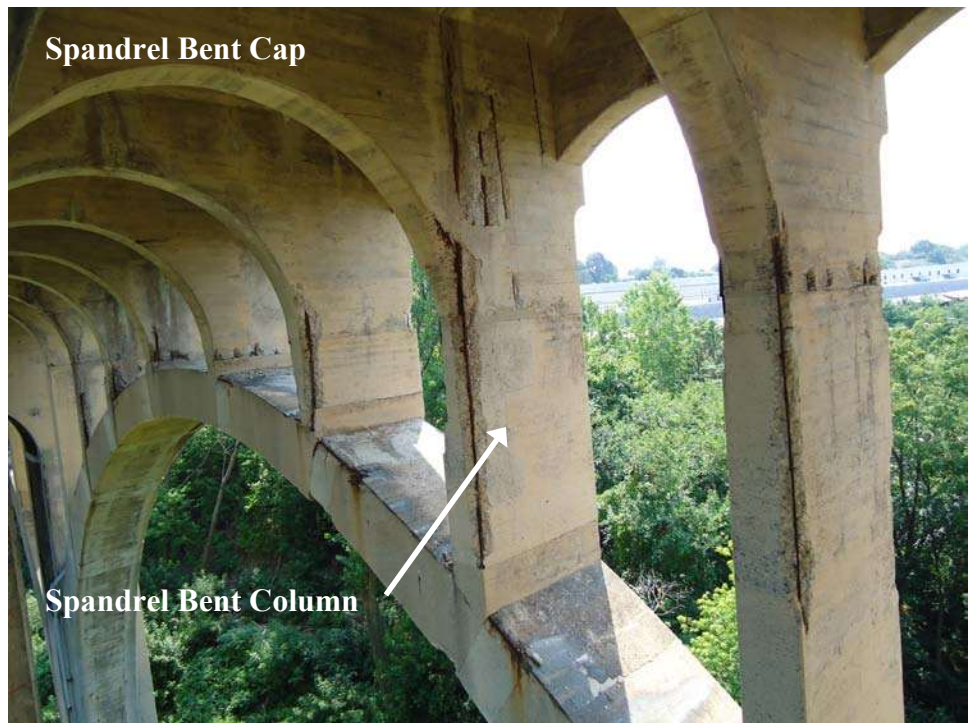
The spandrel column/cap interface has the third greatest bearing load magnitude. Inspect for loss of section at spalled areas. Examine the column for cracks which begin at the inside corner and propagate upward. These indicate differential arch rib deflections (see Figure 9.5.13).

The floor system/bent cap interface has the smallest bearing load magnitude. Examine bearing areas as described in the deck, tee beam and girder sections.

Examine the arch ring for unsound concrete. Look for rust stains, cracks, discoloration, crushing, and deterioration of the concrete. Inspect the interface between the spandrel wall and the arch for spalls that could reduce the bearing area. Investigate the arch for transverse cracks, which indicate an overstress condition.



**Figure 9.5.12** Arch/Skewback Interface



**Figure 9.5.13** Spandrel Column Bent Cap Interface

### Shear Zones

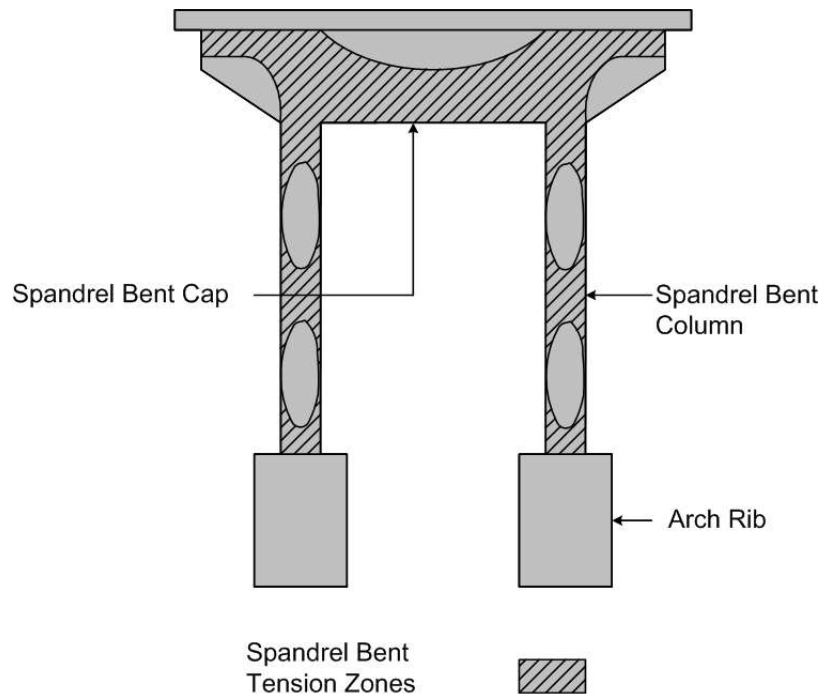
Check for shear cracks at the ends of the spandrel bent caps. When arch ribs are connected with struts, examine the arches near the connection for diagonal cracks due to torsional shear. These cracks indicate excessive differential deflection in the arch ribs. Also investigate the floor system for shear cracks in a fashion similar to tee beams and girders.

### Tension Zones

Inspect the tension areas of the spandrel bent caps and columns (i.e., mid-span at the bottom and ends at the top) (see Figure 9.5.14). Also check the tension areas in the floor system.

Check for transverse cracks in the arch which indicate an overstress condition. Transverse cracks are oriented perpendicular to the arch member.

Inspect the spandrel walls for sound concrete. Look for cracks, movement, and general deterioration of the concrete (see Figure 9.5.15).



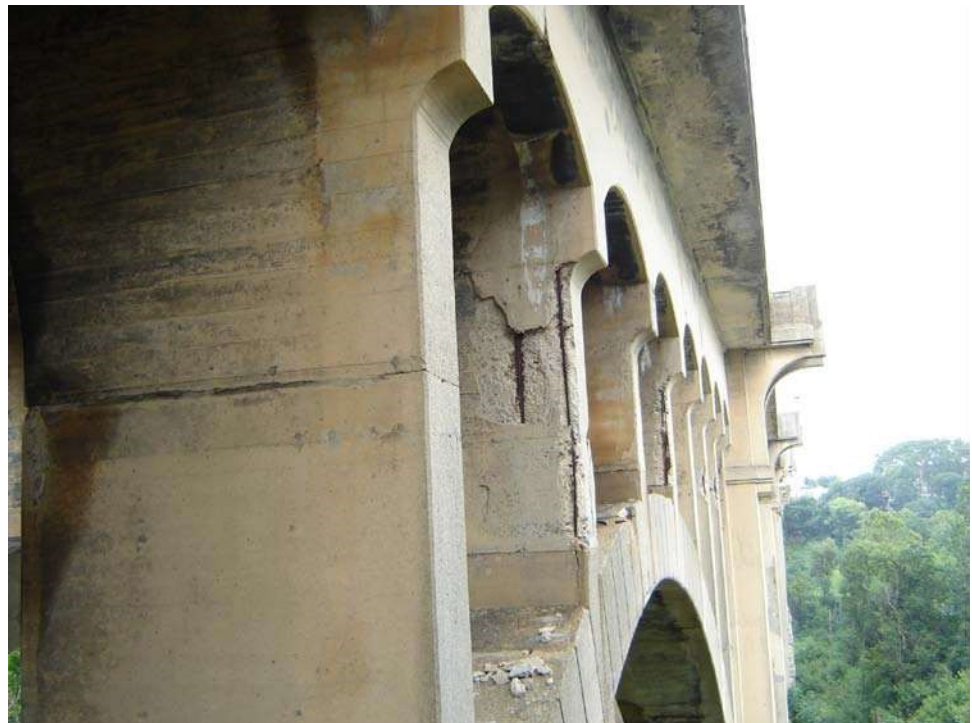
**Figure 9.5.14** Spandrel Bent Tension Zones



**Figure 9.5.15** Deteriorated Arch/Spandrel Wall Interface

### **Compression Zones**

Investigate the compression areas throughout the arches and spandrel columns (not only at the bearing areas). Transverse or lateral cracks indicate excessive surface stresses caused by buckling forces and bending moment (see Figure 9.5.16).



**Figure 9.5.16** Severe Scaling and Spalling on a Spandrel Column

### Movement of Spandrel Wall

Check for movement, or rotation, of the spandrel wall, which is the most common mode of failure for closed spandrel arches.

### Secondary Members

Inspect diaphragms and struts for flexural and shear cracks, as well as for typical concrete deficiencies (see Figure 9.5.17). Deficiencies in the secondary members may be an indication of differential settlement of the substructure or differential deflection of the concrete arches.



**Figure 9.5.17** Inspection and Documentation of Arch Strut Deficiencies

### Areas Exposed to Drainage

For an open spandrel arch, check the areas exposed to drainage and roadway runoff. Elements beneath the floor system are prone to scaling, spalling, and chloride contamination (see Figure 9.5.18).



**Figure 9.5.18** Scaling and Contamination on an Arch Rib Due to a Failed Drainage System

For a closed spandrel arch, verify that the weep holes are working properly. Also, check that surface water drains properly and does not penetrate the fill material.

#### **Areas Exposed to Traffic**

Check deficiency areas by collision. Document the number of exposed and severed reinforcing bars with section loss as well as the spalled and delaminated concrete. The loss of concrete due to such an accident is not always serious, unless the bond between the concrete and steel reinforcement is affected.

#### **Areas Previously Repaired**

Examine thoroughly any repairs that have been previously made. Determine if repaired areas are functioning properly. Effective repairs and patching are usually limited to protection of exposed reinforcement.

#### **Other Areas Exposed to External Damage**

- Waterborne debris or ice
- Fire
- Equipment hits
- Displacement of superstructure due to floods, storm surges, etc.

### **9.5.5**

---

#### **Evaluation**

State and Federal rating guideline systems have been developed to aid in the inspection of concrete bridges. The two major rating guideline systems currently in use are the FHWA's *Recording and Coding Guide for the Structural Inventory and Appraisal of the Nation's Bridges* used for the National Bridge Inventory (NBI) component condition rating method and the AASHTO *Guide Manual for Bridge Element Inspection* for element level condition state assessment.

#### **NBI Component Condition Rating Guidelines**

Using NBI component condition rating guidelines, a one-digit code on the Federal Structure Inventory and Appraisal (SI&A) sheet indicates the condition of the superstructure. Component condition rating codes range from 9 to 0, where 9 is the best rating possible. Consider the previous inspection data along with current inspection findings to determine the correct component condition rating. See Topic 4.2 (Item 59) for additional details about NBI component condition rating guidelines.

Consider previous inspection data along with current inspection findings to determine the correct component condition rating.

#### **Element Level Condition State Assessment**

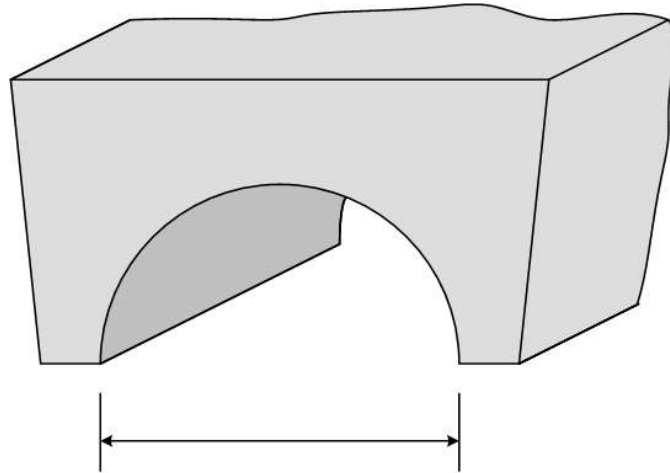
In an element level condition state assessment of a concrete arch, possible AASHTO National Bridge Elements (NBEs) and Bridge Management Elements (BMEs) are:

<u>NBE No.</u>	<u>Description</u>
<b>Superstructure</b>	
<b>Open Spandrel Arch</b>	
109	Prestressed Concrete Girder/Beam
110	Reinforced Concrete Girder/Beam
154	Prestressed Concrete Floorbeam
155	Reinforced Concrete Floorbeam
115	Prestressed Concrete Stringer (stringer-floorbeam system)
116	Reinforced Concrete Stringer (stringer-floorbeam system)
143	Prestressed Concrete Arch
144	Reinforced Concrete Arch
<b>Closed Spandrel Arch</b>	
143	Prestressed Concrete Arch
144	Reinforced Concrete Arch

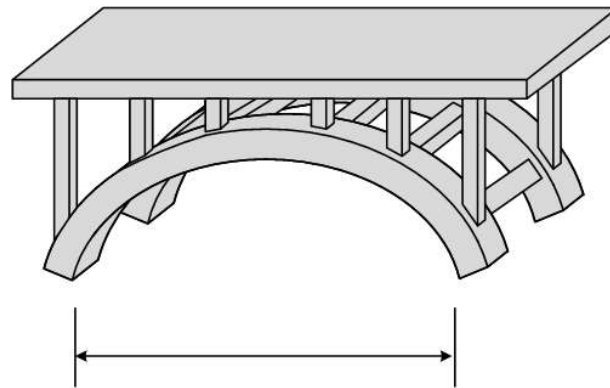
<u>BME No.</u>	<u>Description</u>
<b>Wearing Surfaces and Protection Systems</b>	
521	Concrete Protective Coating

The unit quantity for concrete arch superstructure elements is feet. The total length is distributed among the four available condition states depending on the extent and severity of the deficiency (refer to Figure 9.5.19 for closed spandrel arch measurements). The unit quantity for protective coatings is square feet, with the total area distributed among the four available condition states depending on the extent and severity of the deficiency. The sum of all condition states equals the total quantity of the National Bridge Element or Bridge Management Element. Condition State 1 is the best possible rating. See the *AASHTO Guide Manual for Bridge Element Inspection* for condition state descriptions. Note the condition of the spandrel walls and spandrel columns in the concrete arch elements.





Measurement for Closed Spandrel Arch



Measurement for Open Spandrel Arch

**Figure 9.5.19** Measurements for Open and Closed Spandrel Arches

The following Defect Flags are applicable in the evaluation of arch superstructures:

<b><u>Defect Flag No.</u></b>	<b><u>Description</u></b>
358	Concrete Cracking
359	Concrete Efflorescence
360	Settlement
361	Scour
362	Superstructure Traffic Impact (load capacity)

See the AASHTO *Guide Manual for Bridge Element Inspection* for the application of Defect Flags.

# Table of Contents

## Chapter 9 Inspection and Evaluation of Concrete Superstructures

---

9.6	Concrete Rigid Frames.....	9.6.1
9.6.1	Introduction .....	9.6.1
9.6.2	Design Characteristics .....	9.6.1
	General.....	9.6.1
	Primary and Secondary Members.....	9.6.2
	Steel Reinforcement.....	9.6.3
	Primary Reinforcement .....	9.6.4
	Secondary Reinforcement .....	9.6.5
9.6.3	Overview of Common Deficiencies .....	9.6.6
9.6.4	Inspection Methods and Locations .....	9.6.6
	Methods .....	9.6.6
	Visual .....	9.6.6
	Physical .....	9.6.6
	Advanced Inspection Methods .....	9.6.7
	Locations .....	9.6.7
	Bearing Areas.....	9.6.7
	Shear Zones.....	9.6.8
	Tension Zones.....	9.6.8
	Compression Zones.....	9.6.8
	Secondary Members.....	9.6.9
	Areas Exposed to Drainage.....	9.6.9
	Areas Exposed to Traffic.....	9.6.10
	Areas Previously Repaired.....	9.6.11
	Others Areas Exposed to External Damage .....	9.6.11
	Camber .....	9.6.11
	Thermal Effects.....	9.6.11
9.6.5	Evaluation .....	9.6.11
	NBI Component Condition Rating Guidelines.....	9.6.11
	Element Level Condition State Assessment.....	9.6.12

This page intentionally left blank.

# Topic 9.6 Concrete Rigid Frames

## 9.6.1

### Introduction

A concrete rigid frame structure is a bridge type in which the superstructure and substructure components are constructed as a single unit. Rigid frame action is characterized by the ability to transfer moments at the knee, the intersection between the frame legs and the frame beams or slab. Reinforced concrete rigid frame bridges are either cast-in-place or precast units.

## 9.6.2

### Design Characteristics

#### General

The rigid frame bridge can either be single span or multi-span (see Figure 9.6.1). Single span frame bridges generally utilize slabs to span up to 50 feet. The basic single span frame shape is most easily described as an inverted "U" (see Figure 9.6.2).



**Figure 9.6.1** Multi-span Concrete Rigid Frame Bridges

Multi-span frame bridges are used for spans over 50 feet with slab or rectangular beam designs. Other common multi-span frame shapes include the basic rectangle, and the slant leg or K-frame (see Figure 9.6.3). Due to frame action between the horizontal members and the vertical or inclined members, multi-span frames are considered continuous.



**Figure 9.6.2** Single-span Rectangular Concrete Rigid Frame Bridge

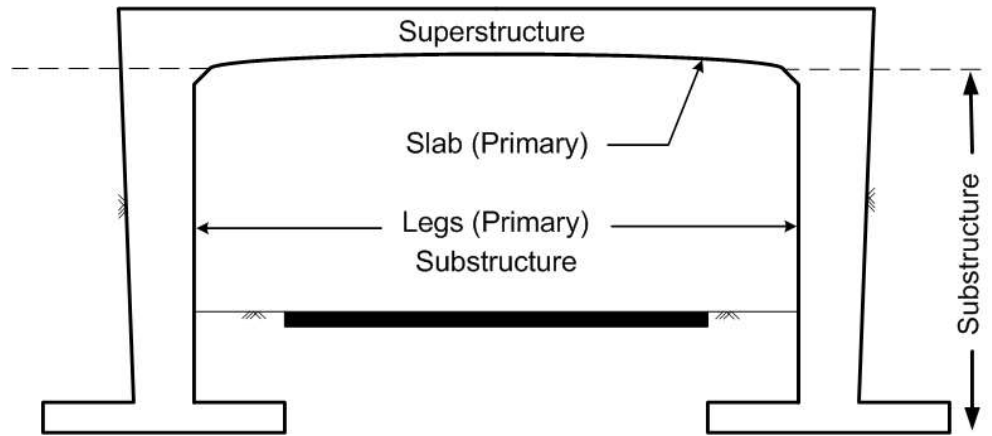
Rigid frame structures are utilized both at grade and under fill, such as in concrete frame culverts (see Topics 14.1 and 14.2).



**Figure 9.6.3** Three Span Concrete K-frame Bridge

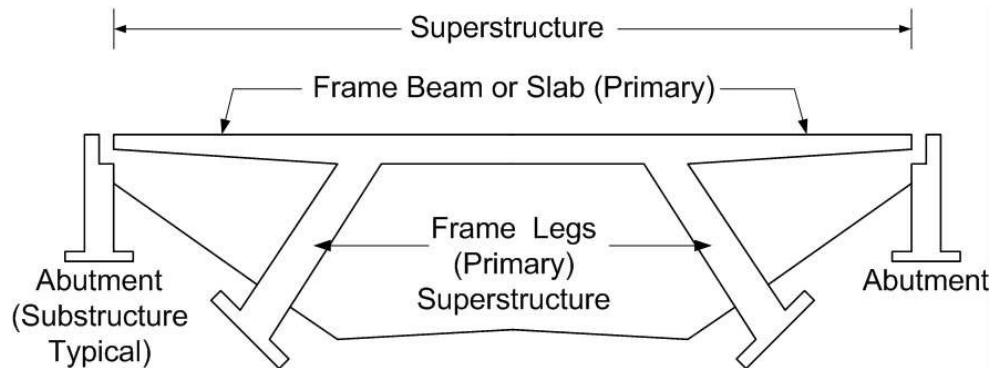
**Primary and Secondary Members**

For single span frames, the primary member is considered to be the slab portion and the legs of the frame (see Figure 9.6.4). For state and federal rating evaluation, the slab portion is considered the superstructure while the legs are considered the substructure. Secondary member diaphragms may be present between frame legs or frame beams. They are not very common in this bridge type.



**Figure 9.6.4** Elevation of a Single Span Frame

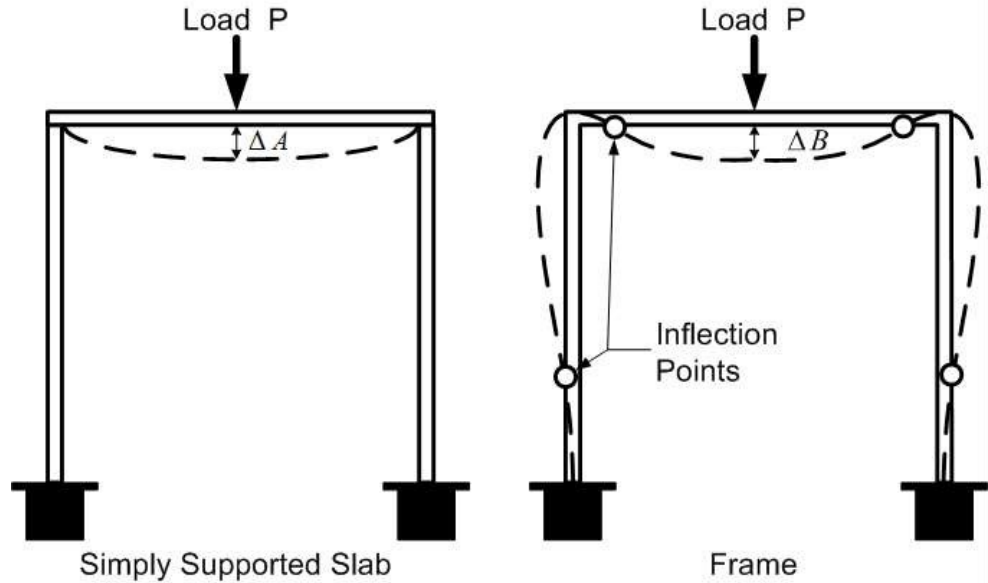
For multi-span frames, the primary members include the frame legs (the slanted beam portions which replace the piers) and the frame beams or slab (the horizontal portion which is supported by the frame legs and abutments) (see Figure 9.6.5). For state and federal rating evaluation, the frame beams or slabs and frame legs are considered the superstructure while the abutments are considered the substructure.



**Figure 9.6.5** Elevation of a K-frame

### Steel Reinforcement

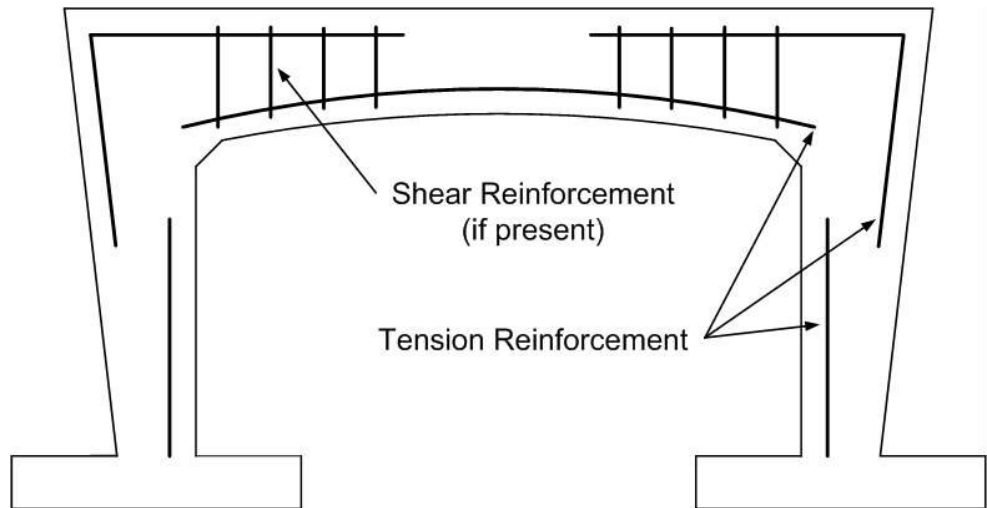
Rigid frame structures develop positive and negative moment throughout due to the interaction of the frame legs and frame beams (see Figure 9.6.6). In slab or beam frames, the primary reinforcement is used to resist tension and possibly shear.



**Figure 9.6.6** Deflected Simply Supported Slab versus Deflected Frame Shape

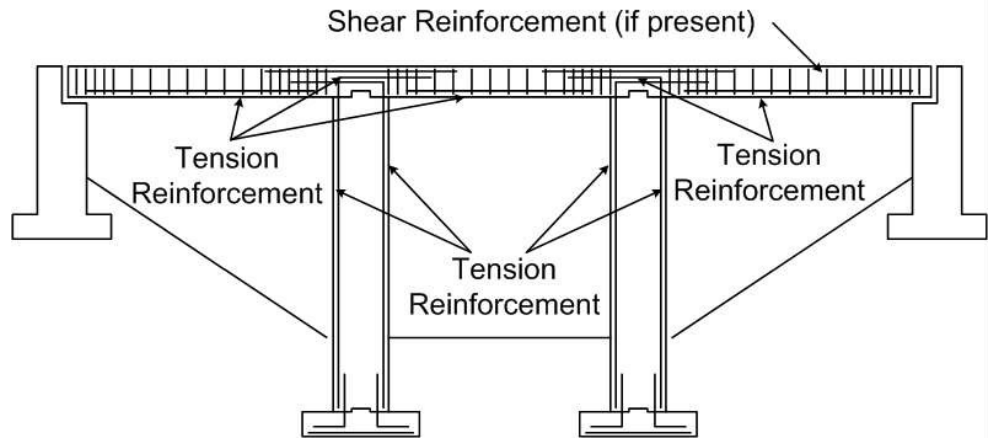
### Primary Reinforcement

For gravity and traffic loads on single span slab frames, the tension steel is placed longitudinally in the bottom of the frame slab, vertically in the front face of the frame legs, and longitudinally and vertically in the outside corners of the frame (see Figure 9.6.7).



**Figure 9.6.7** Primary Reinforcement in a Single Span Frame

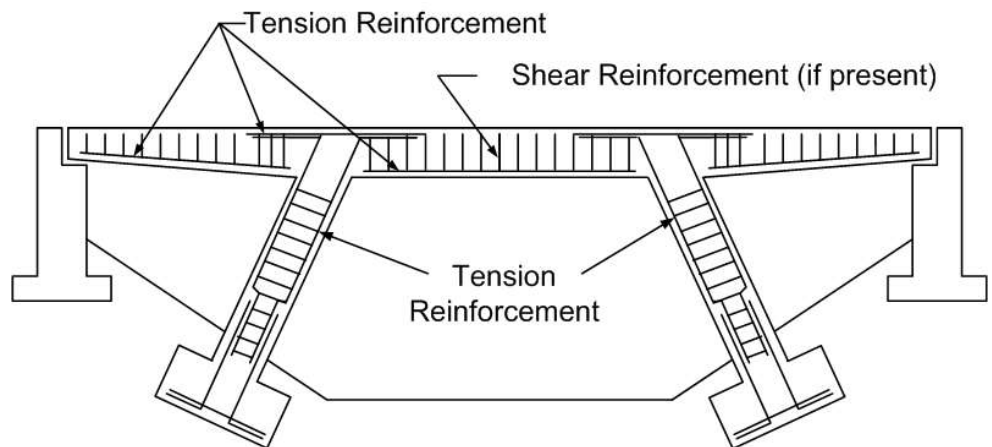
For multi-span slab frames, the tension steel is placed longitudinally in the top and bottom of the frame slab and vertically in both faces of the frame legs (see Figure 9.6.8). If shear reinforcement is required, stirrups are provided.



**Figure 9.6.8** Primary Reinforcement in a Multi-span Slab or Beam Frame

The primary reinforcement in the frame beam portion is longitudinal tension and shear stirrup steel if required, similar to continuous beam reinforcement (see Topic 9.2.2).

In the frame legs, the primary reinforcement is tension and shear steel near the top and compression steel with ties for the remaining length (see Figure 9.6.9). See Topic 12.2 for a discussion of compression steel and column ties.



**Figure 9.6.9** Primary Reinforcement in a K-frame

### Secondary Reinforcement

Temperature and shrinkage reinforcement is distributed similar to that of a slab (see Topic 9.1.2) or tee-beam (see Topic 9.2.2) or box beams (see Topic 9.10.2).



### 9.6.3

---

#### Overview of Common Deficiencies

Common deficiencies that occur on concrete rigid frame bridges include:

- Cracking (structural, flexure, shear, crack size, nonstructural, crack orientation)
- Scaling
- Delamination
- Spalling
- Chloride contamination
- Freeze-thaw
- Efflorescence
- Alkali silica reactivity (ASR)
- Ettringite formation
- Honeycombs
- Pop-outs
- Wear
- Collision damage
- Abrasion
- Overload damage
- Internal steel corrosion
- Loss of prestress
- Carbonation

Refer to Topic 6.2.6 for a detailed explanation of the properties of concrete, types and causes of concrete deficiencies, and the examination of concrete.

### 9.6.4

---

#### Inspection Methods and Locations

Inspection methods to determine causes of concrete deficiencies are presented in detail in Topic 6.2.8.

#### Methods

##### Visual

The inspection of concrete rigid frames for surface cracks, spalls, and other deficiencies is primarily a visual activity.

##### Physical

Sounding by hammer or chain drag can be used to detect delaminated areas. A delaminated area will have a distinctive hollow "clacking" sound when tapped with a hammer or revealed with a chain drag. A hammer hitting sound concrete will result in a solid "pinging" type sound.

### **Advanced Inspection Methods**

Several advanced methods are available for concrete inspection. Nondestructive methods, described in Topic 15.2.2, include:

- Acoustic wave sonic/ultrasonic velocity measurements
- Electrical methods
- Delamination detection machinery
- Ground-penetrating radar
- Electromagnetic methods
- Pulse velocity
- Flat jack testing
- Impact-echo testing
- Infrared thermography
- Laser ultrasonic testing
- Magnetic field disturbance
- Neutron probe for detection of chlorides
- Nuclear methods
- Pachometer
- Rebound and penetration methods
- Ultrasonic testing
- Smart Concrete
- Carbonation

Other inspection methods or tests for material properties, described in Topic 15.2.3, include:

- Concrete permeability
- Concrete strength
- Endoscopes and videoscopes
- Moisture content
- Petrographic examination
- Reinforcing steel strength
- Chloride test
- Matrix analysis
- ASR evaluation

### **Locations**

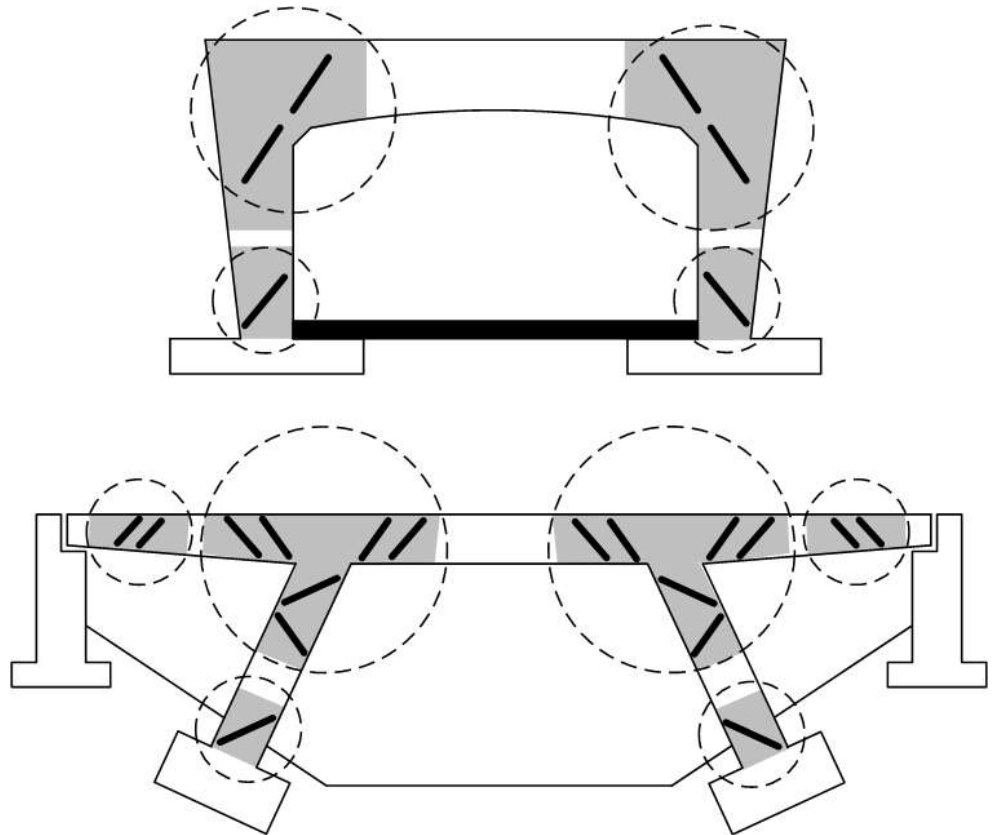
#### **Bearing Areas**

Examine the bearing areas for cracking, delamination or spalling where friction from thermal movement and high bearing pressure could overstress the concrete. Check for crushing of the slab or frame beams over the frame legs. Check the condition of the bearings, if present.

### Shear Zones

Inspect the area near the supports where the frame beams or slab meet the frame legs or abutments. Look for shear cracks in the frame beams or slab (beginning at the frame legs and propagating upward toward mid-span).

Inspect the frame legs for diagonal cracks that initiated at the frame beam/slab or footing (see Figure 9.6.10).



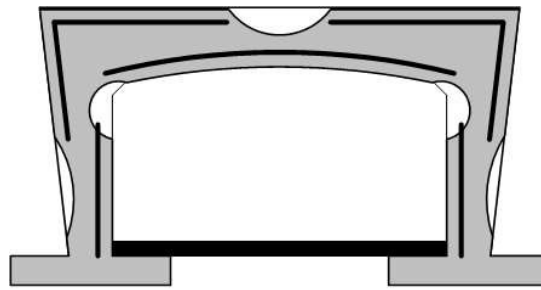
**Figure 9.6.10** Shear Zones in Single Span and Multi-span Frames


### Tension Zones

Inspect the tension areas for flexure cracks, rust stains, efflorescence, exposed and corroded reinforcement, and deteriorated concrete which would cause debonding of the tension reinforcement. The tension areas are located at the bottom of the frame beam at mid-span, the base of each frame leg (usually buried), and the inside faces of the frame legs at mid-height of single span slab frames (see Figures 9.6.11 and 9.6.12).

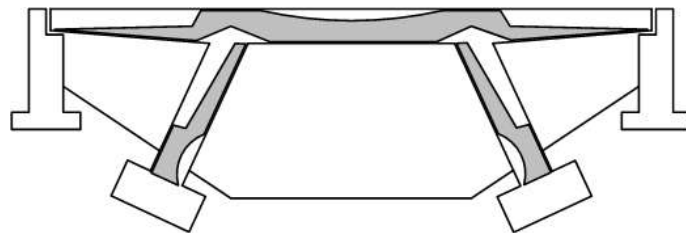
### Compression Zones



Investigate the compression areas for delamination, spalling, scaling, crushing, and exposed reinforcement. The legs of a frame act primarily as columns with a moment applied at the top (see Figures 9.6.11 and 9.6.12). Check the entire length of the frame legs for horizontal cracks, which indicate crushing.



Tension Zones   
Compression Zones 

**Figure 9.6.11** Tension and Compression Zones in a Single Span Frame



Tension Zones   
Compression Zones 

**Figure 9.6.12** Tension and Compression Zones in a Multi-span Frame

### Secondary Members

Secondary members are not common for this bridge type. Inspect secondary members (including diaphragms) for flexural and shear cracks as well as typical concrete deficiencies. Deficiencies in secondary members may be an indication of differential settlement of the substructure or differential deflection of the rigid frames.

### Areas Exposed to Drainage

Examine the areas exposed to drainage for deteriorated and contaminated concrete. Check the roadway surface of the slab or frame beams for delamination and spalls (see Figure 9.6.13). Give special attention to the tension zones and water tables.



**Figure 9.6.13** Roadway of a Rigid Frame Bridge with Asphalt Wearing Surface

Check longitudinal joint areas of adjacent slab or frame beams for leakage and concrete deterioration (see Figure 9.6.14). Check around scuppers and drain holes for deteriorated concrete. Check slab or frame beam ends for deterioration due to leaking deck joints at the abutments. Check to see if weep holes are functioning



**Figure 9.6.14** Longitudinal Joint Between Slab Frames

#### **Areas Exposed to Traffic**

Check areas damaged by collision. Document the number of exposed and severed reinforcing bars with section loss as well as the spalled and delaminated concrete. The loss of concrete due to such an accident is not always serious, unless the bond between the concrete and steel reinforcement is affected.

### **Areas Previously Repaired**

Examine thoroughly any repairs that have been previously made. Determine if repaired areas are functioning properly. Effective repairs and patching are usually limited to protection of exposed reinforcement.

### **Other Areas Exposed to External Damage**

- Waterborne debris or ice
- Fire
- Equipment hits
- Displacement of superstructure due to floods, storm surges, etc.

### **Camber**

Using a string line, check for vertical alignment (camber) changes from the as-built condition of the rigid frame beam/slab. Downward deflection usually indicates reduced capacity. Upward deflection usually indicates shrinkage.

### **Thermal Effects**

These cracks are caused by non-uniform temperatures between two surfaces of the rigid frame. Cracking will typically be transverse in the thinner regions of the tee-beam (such as the deck) and longitudinal near changes in cross section thickness (such as within the knee area).

## **9.6.5**

### **Evaluation**

State and Federal rating guideline systems have been developed to aid in the inspection of concrete bridges. The two major rating guideline systems currently in use are the FHWA's *Recording and Coding Guide for the Structural Inventory and Appraisal of the Nation's Bridges* used for the National Bridge Inventory (NBI) component condition rating method and the AASHTO *Guide Manual for Bridge Element Inspection* for element level condition state assessment.

### **NBI Component Condition Rating Guidelines**

Using NBI component condition rating guidelines, a one-digit code on the Federal Structure Inventory and Appraisal (SI&A) sheet indicates the condition of the superstructure. Component condition rating codes range from 9 to 0, where 9 is the best rating possible. See Topic 4.2 (Item 59) for additional details about NBI component condition rating guidelines.

Consider previous inspection data along with current inspection findings to determine the correct component condition rating.

**Element Level Condition State Assessment** There is no specific element level condition state assessment of a concrete rigid frame bridges. Possible AASHTO National Bridge Elements (NBEs) and Bridge Management Elements (BMEs) that may be used to best describe a concrete rigid frame are:

<u>NBE No.</u>	<u>Description</u>
<u>Decks/Slabs</u>	
38	Reinforced Concrete Slab* * Note that this element designation is used regardless of the type of riding surface
<u>Superstructure</u>	
105	Reinforced Concrete Closed Web/Box Girder
110	Reinforced Concrete Girder/Beam
<u>Substructure**</u>	
205	Reinforced Concrete Column/Pile Extension
210	Reinforced Concrete Pier Wall
215	Reinforced Concrete Abutment

\*\*Note: AASHTO does not have a National Bridge Element designation for superstructure columns, pier walls, and abutments. AASHTO substructure NBE designations are used to represent these elements. This is applicable for single span bridges.

<u>BME No.</u>	<u>Description</u>
<u>Wearing Surfaces and Protection Systems</u>	
520	Deck/Slab Protection Systems
521	Concrete Protective Coating

The unit quantity for slabs, protection systems and protective coatings is square feet. The total area is distributed among the four available condition states depending on the extent and severity of the deficiency. The unit quantity for the girder/beam, abutment, and pier wall is feet, and the total length is distributed among the four condition states depending on the extent and severity of the deficiency. The sum of all condition states equals the total quantity of the National Bridge Element or Bridge Management Element. The unit quantity for column/pile extensions is each and the entire element is placed in one of the four available condition states. Condition State 1 is the best possible rating. See the *AASHTO Guide Manual for Bridge Element Inspection* for condition state descriptions.

The following Defect Flags are applicable in the evaluation of concrete rigid frame superstructures:

<b><u>Defect Flag No.</u></b>	<b><u>Description</u></b>
358	Concrete Cracking
359	Concrete Efflorescence
360	Settlement
362	Superstructure Traffic Impact (load capacity)

See the AASHTO *Guide Manual for Bridge Element Inspection* for the application of Defect Flags.



This page intentionally left blank.

# Table of Contents

## Chapter 9

---

### Inspection and Evaluation of Concrete Superstructures

9.7	Precast and Prestressed Slabs.....	9.7.1
9.7.1	Introduction.....	9.7.1
9.7.2	Design Characteristics.....	9.7.1
	General.....	9.7.1
	Monolithic Behavior.....	9.7.2
	Identifying Voided Slabs.....	9.7.2
	Poutre Dalle System.....	9.7.2
	Primary and Secondary Members.....	9.7.3
	Steel Reinforcement.....	9.7.3
	Primary Reinforcement.....	9.7.3
	Secondary Reinforcement.....	9.7.4
9.7.3	Overview of Common Deficiencies.....	9.7.4
9.7.4	Inspection Methods and Locations.....	9.7.5
	Methods.....	9.7.5
	Visual.....	9.7.5
	Physical.....	9.7.5
	Advanced Inspection Methods.....	9.7.5
	Locations.....	9.7.6
	Bearing Areas.....	9.7.6
	Shear Zones.....	9.7.6
	Tension Zones.....	9.7.7
	Shear Keys.....	9.7.8
	Joints.....	9.7.8
	Areas Exposed to Drainage.....	9.7.8
	Areas Exposed to Traffic.....	9.7.9
	Areas Previously Repaired.....	9.7.9
	Other Areas Exposed to External Damage.....	9.7.9
	Acute Angles on Skewed Bridges.....	9.7.9
	Post-Tensioned Grout Pockets.....	9.7.9
	Camber.....	9.7.9
	Thermal Effects.....	9.7.9
9.7.5	Evaluation.....	9.7.10
	NBI Component Condition Rating Guidelines.....	9.7.10
	Element Level Condition State Assessment.....	9.7.10

This page intentionally left blank.

# Topic 9.7 Precast and Prestressed Slabs

## 9.7.1

### Introduction

Precast and prestressed slabs have gained popularity since the 1950's. This type of design acts as a deck and superstructure combined (see Figure 9.7.1). Individual members are placed side by side and connected together so they act as one slab. When vertical clearances are lacking, this type of design is effective, due to the slab's shallow depth. Wearing surfaces are generally applied to the top of precast and prestressed slabs and are either concrete or bituminous.



**Figure 9.7.1** Typical Prestressed Slab Beam Bridge

Although precast and prestressed slabs are different from concrete decks, the design characteristics, wearing surfaces, protection systems, common deficiencies, inspection procedures and locations, evaluation, and motorist safety concerns are similar to concrete decks. Refer to Topic 7.2 for additional information about concrete decks. For the purpose of this manual, decks are supported by superstructure members while slabs are supported by substructure units.

## 9.7.2

### Design Characteristics

#### General

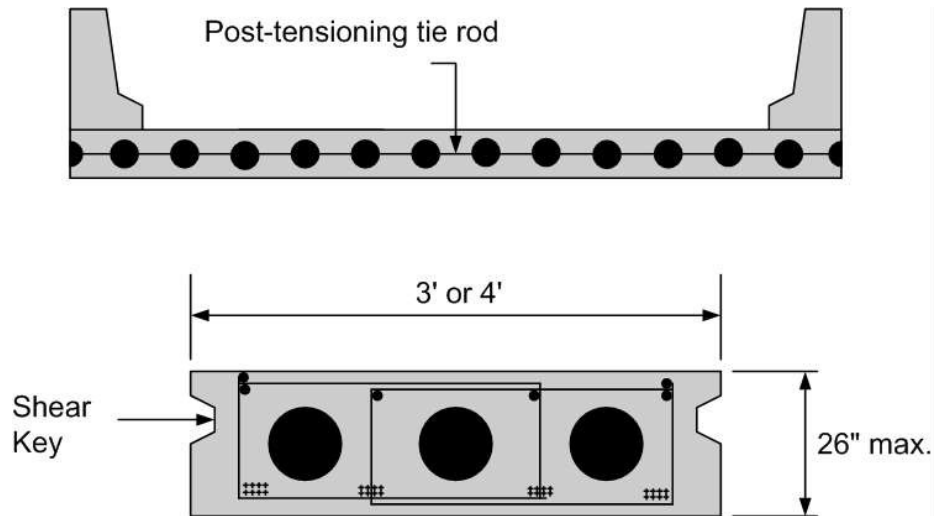
The precast voided slab bridge is the modern replacement of the cast-in-place slab. This type of bridge superstructure is similar to the cast-in-place slab in appearance only. It is comprised of individual precast slab beams fabricated with circular

voids. The voids afford economy of material and reduce dead load (see Figure 9.7.2). Precast slab bridges with very short spans may not contain voids. Precast slabs also contain drain holes, which are strategically placed in the bottom of the slab to allow accumulated moisture to escape.

Precast slab units are practical for spans up to 60 feet. The slabs can be single or multiple simple spans. The units are typically 36 or 48 inches wide and have a depth of up to 26 inches.

Prestressed precast units are generally comprised of 4,000 to 8,000 psi prestressed concrete and reinforced with 270 ksi pre- or post-tensioned steel tendons.

Conventional concrete precast slabs with compressive strength of 3000 to 4000 psi and reinforcement of 40 ksi or 60 ksi can also be fabricated but are less common than prestressed precast slabs.



**Figure 9.7.2** Cross Section of a Typical Voided Slab

**Monolithic Behavior**

Adjacent slab units may be post-tensioned together with tie rods having a tensile capacity of 145 ksi and grouted at the shear keys. Together these enable the slab units to act monolithically.

**Identifying Voided Slabs**

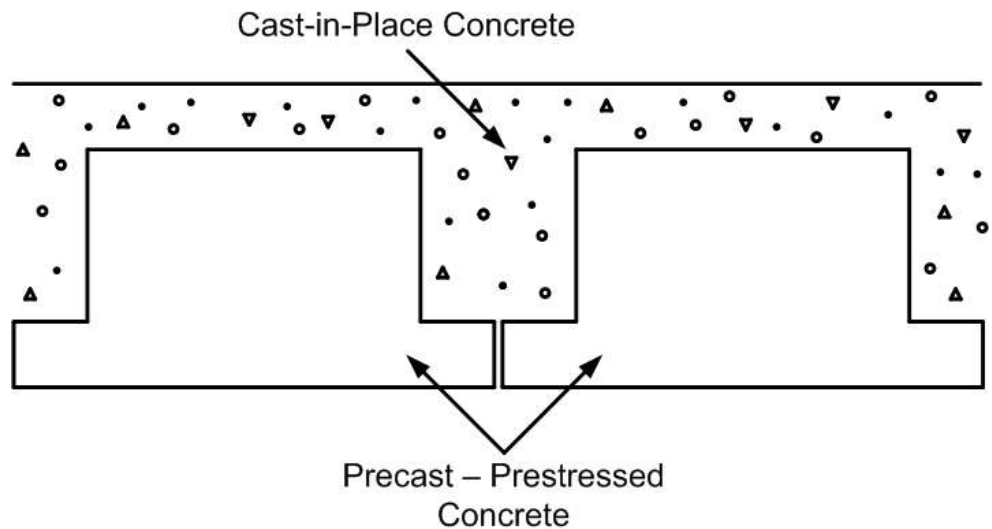
Physical dimensions alone are not enough to distinguish a slab unit from a box beam. Design or construction plans need to be reviewed. A box beam has one rectangular void, bounded by a top flange, bottom flange, and two webs. A typical box beam has a minimum depth of 12 inches, but may be as deep as 72 inches. A typical voided slab section has two or three circular voids through it. It is also possible to find precast solid slab units.

**Poutre Dalle System**

Recent technology has also produced the inverted tee beam, a new type of precast slab, for short to medium span bridges known as the Poutre Dalle system. Developed in France, the Poutre Dalle precast segments can span up to 82 feet with a maximum span of 105 feet. The overall composite depth of the spans is  $1/28^{\text{th}}$  to  $1/30^{\text{th}}$  of the span length with a width of 16 to 79 inches (see Figures 9.7.3 and 9.7.4). Beam depth may also be reduced for applications utilizing shorter spans. The combination of strength and size allows this beam type to compete as favorable alternative to precast solid slabs.



**Figure 9.7.3** Poutre Dalle Precast Slab Bridge



**Figure 9.7.4** Poutre Dalle Bridge Schematic

**Primary and Secondary Members**

The primary members of a precast voided slab bridge are the individual slab units. The slab units make up the superstructure and the deck and are commonly protected by an asphalt or concrete overlay. There are no secondary members.

**Steel Reinforcement**

**Primary Reinforcement**

The primary reinforcement consists of longitudinal tension steel and shear reinforcement or stirrups.

Prestressing strands placed near the bottom of the slab make up the main tension

steel. Depending on the age of the structure, the strand size will be 1/4, 3/8, 7/16, or 1/2 inch diameter. Prestressing strands are normally spaced 2 inches on center (see Figure 9.7.5) and have a tensile strength of 270 ksi. Tension steel for conventionally reinforced precast slabs has a yield strength of 60 ksi or 40 ksi depending on the age of the structure.

Shear reinforcement consists of U-shaped or closed loop stirrups located throughout the slab at various spacings required by design.

### Secondary Reinforcement

Secondary reinforcement is provided to control temperature and shrinkage cracking. This reinforcement is placed longitudinally in the beam, normally at the top of the slab units, and holds the stirrups in place during fabrication.

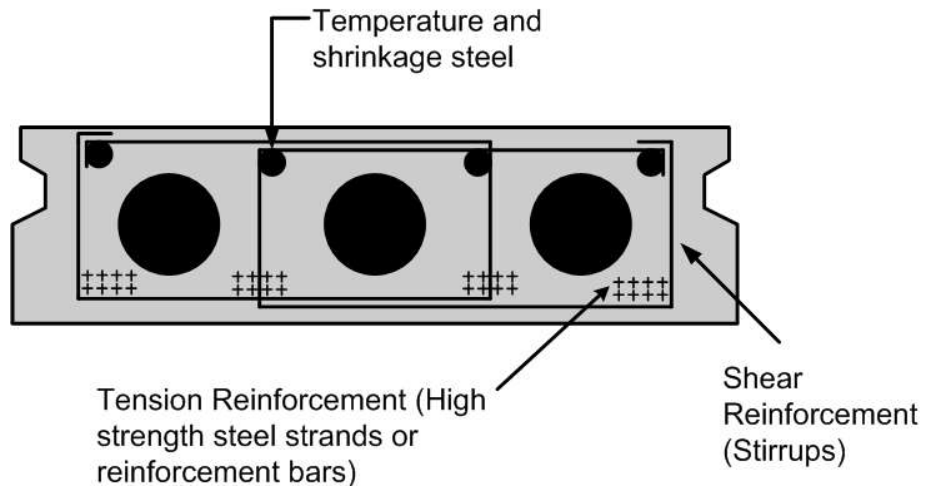


Figure 9.7.5 Slab Beam Bridge Tension and Shear Reinforcement

### 9.7.3

#### Overview of Common Deficiencies

Common deficiencies that occur on precast and prestressed slab bridges include:

- Cracking (structural, flexure, shear, crack size, nonstructural, crack orientation)
- Scaling
- Delamination
- Spalling
- Chloride contamination
- Freeze-thaw
- Efflorescence
- Alkali silica reactivity (ASR)
- Ettringite formation
- Honeycombs
- Pop-outs

- Wear
- Collision damage
- Abrasion
- Overload damage
- Internal steel corrosion
- Loss of prestress
- Carbonation

Refer to Topic 6.2.6 for a detailed presentation of the properties of concrete, types and causes of concrete deficiencies, and the examination of concrete.

## **9.7.4**

### **Inspection Methods and Locations**

Inspection methods to determine causes of concrete deficiencies are presented in detail in Topic 6.2.8.

#### **Methods**

##### **Visual**

The inspection of concrete slabs for surface cracks, spalls, wear, and other deficiencies is primarily a visual activity.

##### **Physical**

The physical examination of the top surface of the slab with a hammer can be a tedious operation. In most cases, a chain drag is used to determine delaminated areas. A chain drag is typically made of several sections of chain attached to a pipe that has a handle attached to it. The inspector drags this across a slab and makes note of the resonating sounds. A delaminated area will have a distinctive hollow "clacking" sound when tapped with a hammer or revealed with a chain drag. A hammer hitting sound concrete will result in a solid "pinging" type sound.

Since prestressed beams are designed to maintain all concrete in compression, cracks are indications of serious problems. For this reason, carefully measure any crack with an optical crack gauge or crack comparator card and document the results.

##### **Advanced Inspection Methods**

Several advanced methods are available for concrete inspection. Nondestructive methods, described in Topic 15.2.2, include:

- Acoustic wave sonic/ultrasonic velocity measurements
- Electrical methods
- Delamination detection machinery
- Ground-penetrating radar
- Electromagnetic methods
- Pulse velocity
- Flat jack testing
- Impact-echo testing
- Infrared thermography



- Laser ultrasonic testing
- Magnetic field disturbance
- Neutron probe for detection of chlorides
- Nuclear methods
- Pachometer
- Rebound and penetration methods
- Ultrasonic testing
- Smart Concrete
- Carbonation

Other inspection methods or tests for material properties, described in Topic 15.2.3, include:

- Concrete permeability
- Concrete strength
- Endoscopes and videoscopes
- Moisture content
- Petrographic examination
- Reinforcing steel strength
- Chloride test
- Matrix analysis
- ASR evaluation

## **Locations**

### **Bearing Areas**

Examine the bearing areas for cracking, delamination or spalling where thermal movement and high bearing pressure could overstress the concrete. End spalling can eventually lead to the loss of bond in the prestressing tendons. Also check bearing areas for deficiencies due to leaking joints.

Check bearing areas for spalls or vertical cracks. Spalls and cracks may be caused by corrosion of steel due to water leakage or restriction of thermal movement due to a faulty bearing mechanism.

### **Shear Zones**

Inspect near the supports for diagonal or shear cracks on the vertical surfaces and along the bottom of the slab units close to the supporting substructure units.

Inspect the top and bottom surface for longitudinal reflective cracking and between the slab sections for leakage (see Figure 9.7.6). These problems indicate failed shear keys and that the slab units are no longer tied together or acting monolithically. Observe if there is differential slab deflection under live load.



**Figure 9.7.6** Leaking Joint between Adjacent Slab Units

### **Tension Zones**

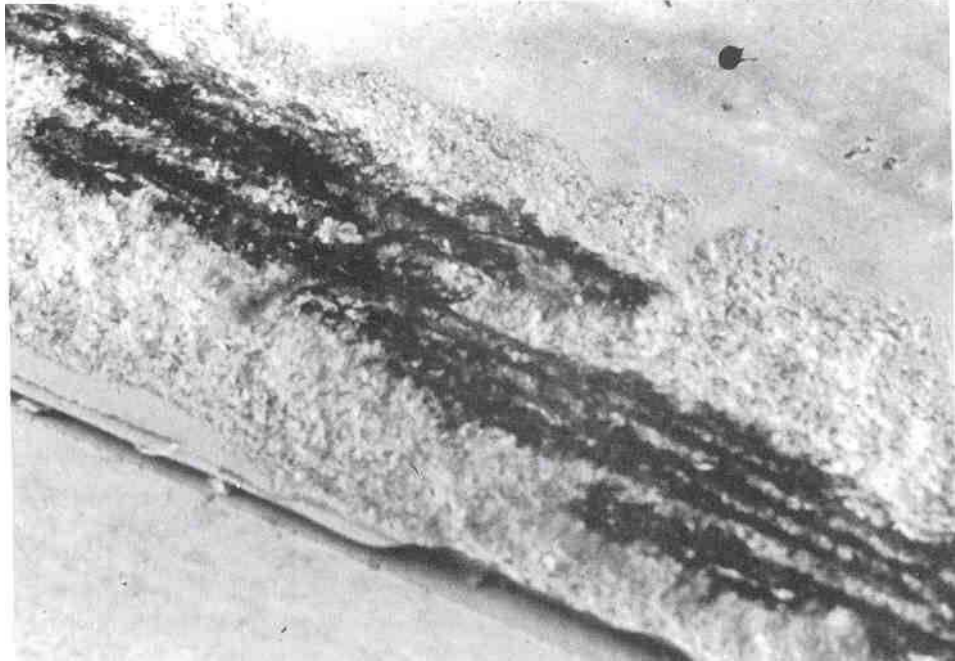
Check the bottom of the slab sections for flexure cracks due to positive moments. Since prestressed concrete is under high compressive forces, no cracks should be present. Cracks can be a serious problem since they indicate overloading or loss of prestress. Cracks that may be present will be difficult to detect with the naked eye. To improve detection, a common practice is to wet the slab surface with water using a spray bottle. Capillary action will draw water into a crack, thus producing a visible line when the surrounding surface water evaporates. Measure all cracks with an optical crack gauge or crack comparator card.

Examine the top of the slab sections (if exposed) near the ends for tensile cracks due to prestress eccentricity. This indicates excessive prestress force. If the top of the slab has a wearing surface applied, check for cracks in the wearing surface. Cracks in the wearing surface may be an indication that the slab is overstressed or that water is getting to the slab.

Investigate for evidence of sagging, which indicates a loss of prestress. Use a string line or site down the bottom edge of the fascia slab unit.

Inspect the slabs for exposed strands. Prestressed strands will corrode rapidly and fail abruptly. Therefore, any exposure is significant (see Figure 9.7.7).

Check for longitudinal cracking in slab members. Water freezing in the voids can cause longitudinal cracks. Skewed slab units may exhibit longitudinal cracks due to uneven prestressing force in the strands.



**Figure 9.7.7** Exposed Strands in a Precast Slab Beam

### **Shear Keys**

In precast and prestressed slab bridges, check each segment for independent vertical deflection, which may indicate failed shear keys, and lateral deflection on the exterior slab segments, which may indicate eccentric loading of the exterior slab segment. Inspect slab joints for signs of leakage between slabs, which is indicative of deteriorated shear key grout material. Independent movement of slab segments decreases the load capacity of the superstructure and need to be coded accordingly and referred to an engineer for evaluation.

### **Joints**

Inspect joints for crushing and movement of the shear keys. The presence of open or loose joints needs to be documented. Areas where the type of construction required closure joints or segments to be poured in place will need close attention. These areas sometimes are regions of tendon anchorages and couplers (if prestressed). The stress concentrations in these areas are very much different than a section away from the anchorages where a distributed stress pattern exists. Additionally, the effects of creep and tendon relaxation are somewhat higher in these regions.

### **Areas Exposed to Drainage**

Inspect areas exposed to drainage for deteriorated and contaminated concrete. This includes the entire riding surface of the slab, particularly around scuppers or drains. Spalling or scaling may also be found along the curbline and fascias.

Inspect longitudinal joints between the precast slabs. Drainage through the joints indicates a broken shear key and loss of monolithic action.

Check that drain holes for voids in slabs are functioning. If not, water can accumulate and cause premature failure of the slab segment.

### **Areas Exposed to Traffic**

When precast voided slab superstructures are used for a grade crossing, check the areas over the traveling lanes for collision damage. This is generally not a problem due to the good vertical clearance afforded by the relatively shallow slab units.

Check areas exposed to wear on the top surface.

### **Areas Previously Repaired**

Examine thoroughly any repairs that have been previously made. Determine if repaired areas are sound and functioning properly. Effective repairs and patching are usually limited to protection of exposed tendons and reinforcement.

### **Other Areas Exposed to External Damage**

- Waterborne debris or ice
- Fire
- Equipment hits
- Displacement of superstructure due to floods, storm surges, etc.

### **Acute Angles on Skewed Bridges**

Examine skewed bridges for lateral displacement and cracking of acute corners due to point loading and insufficient reinforcement.

### **Post-Tensioned Grout Pockets**

Check the condition of the lateral post-tensioning grout pockets and visible ends of the post-tensioning rods. Cracked grout or rust stains may indicate a failure of the post-tensioning rod or loss of monolithic action.

### **Camber**

Using a string line, check for vertical alignment (camber) changes from the as-built condition of the slab units. Loss of positive camber indicates loss of prestress in the tendons.

### **Thermal Effects**

These cracks are caused by non-uniform temperatures between two surfaces of the slab. Cracking will typically be transverse in the thinner regions of the slab and longitudinal near changes in cross section thickness (if applicable).

## 9.7.5

### Evaluation

State and Federal rating guideline systems have been developed to aid in the inspection of concrete superstructures. The two major rating guideline systems currently in use are the FHWA's *Recording and Coding Guide for the Structural Inventory and Appraisal of the Nation's Bridges* used for the National Bridge Inventory (NBI) component condition rating method and the AASHTO *Guide Manual for Bridge Element Inspection* for element level condition state assessment.

### NBI Component Condition Rating Guidelines

Using NBI component condition rating guidelines, a one-digit code on the Federal Structure Inventory and Appraisal (SI&A) sheet indicates the condition of the deck and the superstructure. Component condition rating codes range from 9 to 0, where 9 is the best rating possible. See Topic 4.2 (Items 58 and 59) for additional details about NBI component condition rating guidelines. For a precast or prestressed slab bridge, these guidelines must be applied for both the deck component and the superstructure component.

Consider previous inspection data along with current inspection findings to determine the correct component condition rating.

Typically, for this type of structure, the deck and superstructure components will have the same rating.

### Element Level Condition State Assessment

In an element level condition state assessment of a precast or prestressed slab bridge, possible AASHTO National Bridge Elements (NBEs) and Bridge Management Elements (BMEs) are:

#### NBE No.

#### Description

#### Decks/Slabs

38

Reinforced Concrete Slab\*

\* Note that this element designation is used regardless of the type of riding surface

104

Prestressed Closed Web/box Girder

#### BME No.

#### Description

#### Wearing Surfaces and Protection Systems

510

Wearing Surfaces

520

Deck/Slab Protection Systems

521

Concrete Protective Coating

The unit quantity for slabs, wearing surfaces, protection systems and protective coatings is square feet. The total area is distributed among the four available condition states depending on the extent and severity of the deficiency. Closed web/box girder, NBE No. 104, is the closest choice in the AASHTO element list for precast prestressed voided slabs. The unit quantity for the girder is feet, and the total length is distributed among the available condition states depending on the extent and severity of the deficiency. The sum of all condition states equals the total quantity of the National Bridge Element or Bridge Management Element.

Condition State 1 is the best possible rating. See the AASHTO *Guide for Bridge Element Inspection* for condition state descriptions. States may decide to choose their own element number for precast prestressed voided slabs because AASHTO does not have a specific element number for prestressed slabs.

The following Defect Flags are applicable in the evaluation of precast and prestressed slab superstructures:

<b><u>Defect Flag No.</u></b>	<b><u>Description</u></b>
358	Concrete Cracking
359	Concrete Efflorescence
362	Superstructure Traffic Impact (load capacity)

See the AASHTO *Guide Manual for Bridge Element Inspection* for the application of Defect Flags.

This page intentionally left blank

# Table of Contents

## Chapter 9 Inspection and Evaluation of Concrete Superstructures

---

9.8	Prestressed Double Tees .....	9.8.1
9.8.1	Introduction .....	9.8.1
9.8.2	Design Characteristics .....	9.8.1
	General .....	9.8.1
	Primary and Secondary Members .....	9.8.3
	Steel Reinforcement .....	9.8.3
9.8.3	Overview of Common Deficiencies .....	9.8.4
9.8.4	Inspection Methods and Locations .....	9.8.4
	Methods .....	9.8.5
	Visual .....	9.8.5
	Physical .....	9.8.5
	Advanced Inspection Methods .....	9.8.5
	Locations .....	9.8.6
	Bearing Areas .....	9.8.6
	Shear Zones .....	9.8.6
	Tension Zones .....	9.8.7
	Secondary Members .....	9.8.7
	Joints .....	9.8.7
	Areas Exposed to Drainage .....	9.8.7
	Areas Exposed to Traffic .....	9.8.7
	Areas Previously Repaired .....	9.8.8
	Other Areas Exposed to External Damage .....	9.8.8
	General .....	9.8.8
	Camber .....	9.8.8
	Thermal Effects .....	9.8.8
9.8.5	Evaluation .....	9.8.9
	NBI Component Condition Rating Guidelines .....	9.8.9
	Element Level Condition State Assessment .....	9.8.9



This page intentionally left blank

# Topic 9.8 Prestressed Double Tees

## 9.8.1

### Introduction

A prestressed double tee beam, like the name implies, resembles two adjacent capital letter T's that are side by side (see Figure 9.8.1). The horizontal section is called the deck or flange, and the two vertical leg sections are called the webs or stems. This type of bridge beam is mostly used in short spans or in situations where short, obsolete bridges are to be replaced.



**Figure 9.8.1** Typical Prestressed Double Tee Beam

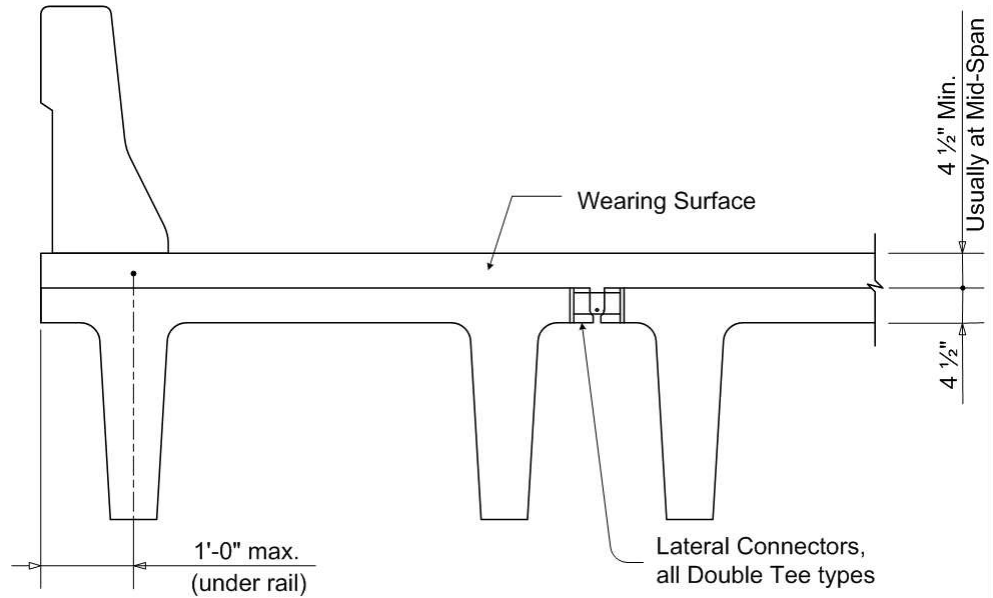
## 9.8.2

### Design Characteristics

#### General

Prestressed concrete double tee beams have a monolithic deck and stem design that allows the deck to act integrally with the stems to form a superstructure. The integral design provides a stiffer member, while the material-saving shape reduces the dead load. Lateral connectors enable load transfer between the individual double tee sections (see Figure 9.8.2).

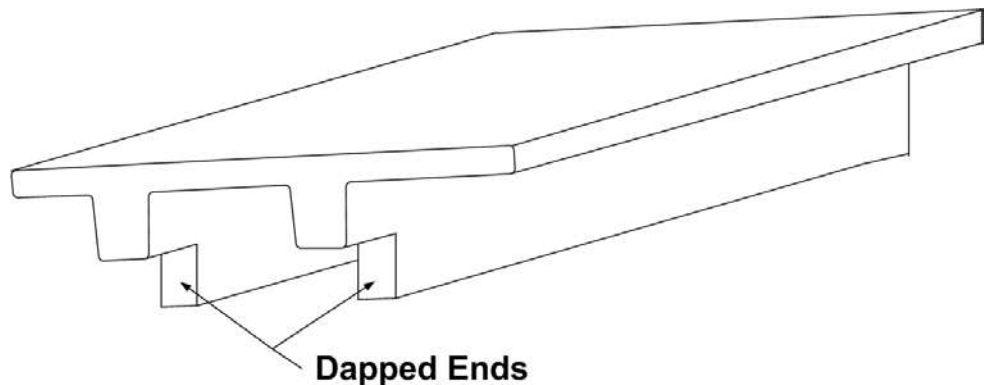
This type of construction was originally used for buildings and is quite common in parking garages. They have been adapted for use in highway structures.



**Figure 9.8.2** Prestressed Double Tee Beam Typical Section

Prestressed double tees have a typical stem depth of 12 to 34 inches. The average flange width is 8 to 10 feet, with a typical span length of approximately 25 to 55 feet. Prestressed double tees can be used in spans approximately 80 feet long with stem depths up to 5 feet and flange widths up to 12 feet. Prestressed double tee bridges are typically simple spans, but continuous spans have also been constructed. Continuity is achieved from span to span by forming the open section between beam ends, placing the required reinforcement, and casting concrete in the void area. Once the concrete reaches its design strength, the spans are considered to be continuous for live load.

In some prestressed double tee designs, the depth of the stems at the beam end is dapped, or reduced (see Figure 9.8.3). This occurs so that the beam end can sit flush on the bearing seat.



**Figure 9.8.3** Dapped End of a Prestressed Double Tee Beam

The top of the flange or deck section of prestressed double tees can act as the integral wearing surface or be overlaid. Bituminous asphalt and concrete are typical examples of wearing surfaces that may be applied. See Topic 7.2.3 for a detailed description of the different types of concrete deck wearing surfaces.

**Primary and Secondary Members**

The primary members of a prestressed double tee beam are the stems and the deck.

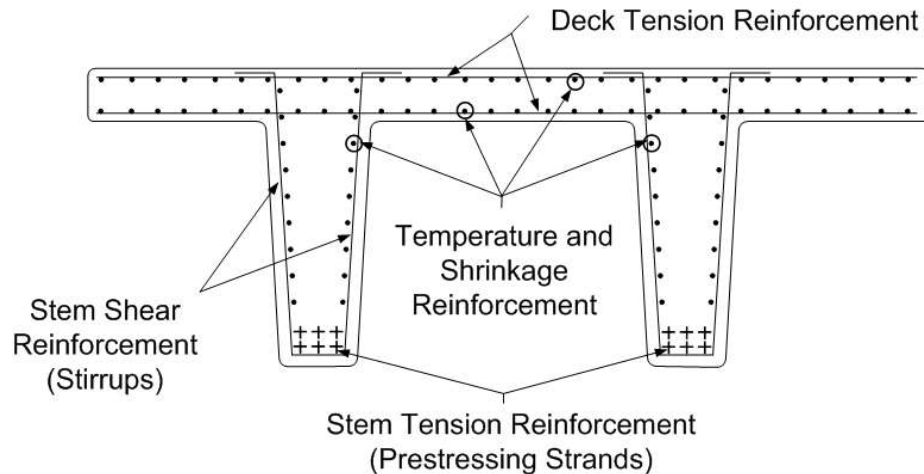
The secondary members of a prestressed double tee bridge are the transverse diaphragms. The diaphragms are located at the span ends. They connect adjacent stems and prevent lateral movement. In the case of longer spans, intermediate diaphragms may also be placed to compensate for torsional forces. The diaphragms can be constructed of reinforced concrete or steel.

**Steel Reinforcement**

The primary tension and shear steel reinforcement consists of prestressing strands and mild reinforcement (see Figure 9.8.4). The prestressing strands are placed longitudinally in each stem at the required spacing and clearance. When the double tees are to be continuous over two or more spans, conduits may be draped through the stems of each span to allow for post-tensioning. The shear reinforcement in a prestressed double tee beam consists of vertical U-shaped stirrups that extend from the stem into the flange. The shear reinforcement or stirrups are spaced along the length of the stem at a spacing required by design. The primary reinforcement for the deck or flange section of a prestressed double tee beam follows the reinforcement pattern of a typical concrete deck (see Topic 7.2.2).

In some wider applications, the deck or flange portions of adjacent prestressed double tee beams may be transversely post-tensioned together through post-tensioning ducts. Transverse post-tensioning decreases the amount of damage that can occur to individual flange sides due to individual deflection and helps the double tee beams deflect as one structure.

The secondary, or temperature and shrinkage, reinforcement is placed longitudinally on each side of each stem and deck. In some newer designs, welded-wire-fabric is used as the secondary and shear reinforcement in the stems. The vertical bars in the welded-wire-fabric act as the shear reinforcement and the longitudinal bars perform as the secondary reinforcement. Tests have shown that temperature and shrinkage cracking can be reduced when welded-wire-fabric is used.



**Figure 9.8.4** Steel Reinforcement in a Prestressed Double Tee Beam

### 9.8.3

#### Overview of Common Deficiencies

Common deficiencies that occur on prestressed concrete double tee beam bridges include:

- Cracking (structural, flexure, shear, crack size, nonstructural, crack orientation)
- Scaling
- Delamination
- Spalling
- Chloride contamination
- Freeze-thaw
- Efflorescence
- Alkali silica reactivity (ASR)
- Ettringite formation
- Honeycombs
- Pop-outs
- Wear
- Collision damage
- Abrasion
- Overload damage
- Internal steel corrosion
- Loss of prestress
- Carbonation

Refer to Topic 6.2.6 for a detailed explanation of the properties of concrete, types and causes of concrete deficiencies, and the examination of concrete.

### 9.8.4

#### Inspection Methods and Locations

Inspection methods to determine causes of concrete deficiencies are presented in detail in Topic 6.2.8.

## Methods

### Visual

The inspection of prestressed double tees for surface cracks, spalls, and other deficiencies is primarily a visual activity.

### Physical

The physical examination of a double tee beam with a hammer can be a tedious operation. In most cases, a chain drag is used to determine areas on the top flange or deck surface. The inspector drags this across a deck and makes note of the resonating sounds. A delaminated area will have a distinctive hollow "clacking" sound when tapped with a hammer or revealed with a chain drag. A hammer hitting sound concrete will result in a solid "pinging" type sound. Hammer sounding is used to examine the stem and bottom surface of the flange.

Since prestressed beams are designed to maintain all concrete in compression, cracks are indications of serious problems. Carefully measure any crack with an optical crack gauge or crack comparator card and document the results.

### Advanced Inspection Methods

Several advanced methods are available for concrete inspection. Nondestructive methods, described in Topic 15.2.2, include:

- Acoustic wave sonic/ultrasonic velocity measurements
- Electrical methods
- Delamination detection machinery
- Ground-penetrating radar
- Electromagnetic methods
- Pulse velocity
- Flat jack testing
- Impact-echo testing
- Infrared thermography
- Laser ultrasonic testing
- Magnetic field disturbance
- Neutron probe for detection of chlorides
- Nuclear methods
- Pachometer
- Rebound and penetration methods
- Ultrasonic testing
- Smart Concrete
- Carbonation

Other inspection methods or tests for material properties, described in Topic 15.2.3, include:

- Concrete permeability
- Concrete strength
- Endoscopes and videoscopes

- Moisture content
- Petrographic examination
- Reinforcing steel strength
- Chloride test
- Matrix analysis
- ASR evaluation

## Locations

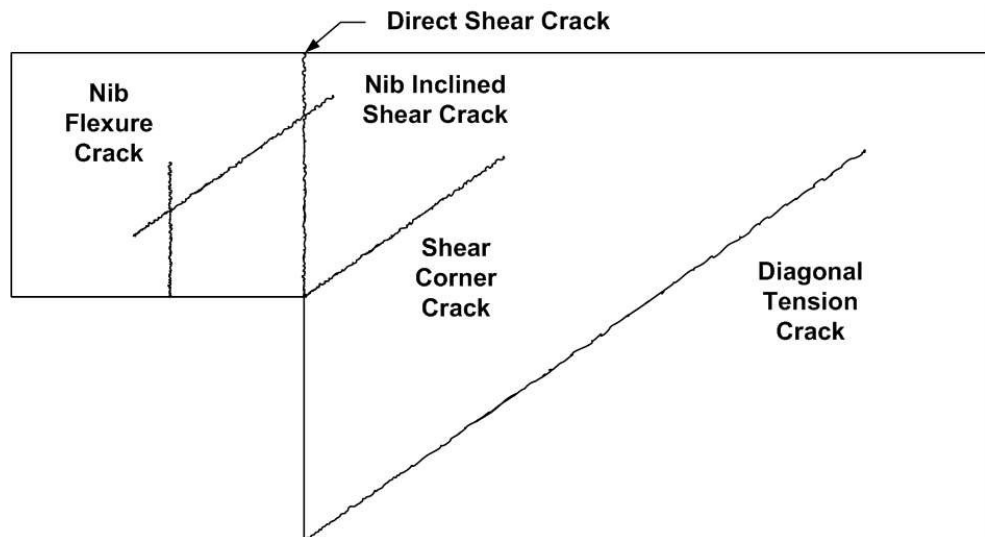
### Bearing Areas

Examine bearing areas for cracking, delamination or spalling where friction from thermal movement and high bearing pressure could overstress the concrete. Check for crushing of the stem near the bearing seat. Check the condition and operation of any bearing devices.

### Shear Zones

Inspect the area near the supports for the presence of shear cracking. The presence of transverse cracks on the underside of the stems or diagonal cracks on the sides of the stem indicate the onset of shear failure. Carefully measure these cracks, as they may represent lost shear capacity.

For dapped-end double tee beams, look for diagonal shear cracks in the reduced depth section that sits on the bearing seat. At the full depth-to-reduced-depth vertical interface, check for vertical direct shear cracking. At the bottom corner where the reduced section meets the full depth section, check for diagonal shear corner cracks. At the bottom corner of the full depth section, check for diagonal tension cracks (see Figure 9.8.5).



**Figure 9.8.5** Crack Locations for Dapped End Double Tee Beams

### **Tension Zones**

Examine tension zones for flexure cracks, which would be transverse across the bottom of the stems and vertical on the sides. The tension zones are at the midspan along the bottom of the stem for both simple and continuous span bridges. Additional tension zones are located on the deck over the piers of continuous spans. For dapped-end double tee beams, look for vertical flexure cracks in the reduced depth section that sits on the bearing seat (see Figure 9.8.5).

Flexural cracks caused by tension due to deck loading will be found on the underside in a longitudinal direction between the stems.

Check for deteriorated concrete near the tension zones, which could result in the debonding of the tension reinforcement. This would include delamination, spalls, and contaminated concrete.

### **Secondary Members**

Inspect diaphragms for flexure and shear cracks as well as typical concrete deficiencies. Cracks in the diaphragms could be an indication of overstress or excessive differential deflection in the double tee beams or differential settlement of the substructure.

### **Joints**

Inspect longitudinal joints for crushing and movement of the shear keys. The presence of open or loose joints needs to be documented. Areas where the type of construction required closure joints or segments to be poured in place will need close attention. These areas sometimes are regions of tendon anchorages and couplers (if prestressed). The stress concentrations in these areas are very much different than a section away from the anchorages where a distributed stress pattern exists. Additionally, the effects of creep and tendon relaxation are somewhat higher in these regions.

### **Areas Exposed to Drainage**

If the roadway surface is bare concrete, check for delamination, scaling and spalls. The curb lines are most suspect. If the deck has an asphalt wearing surface, check for indications of deteriorated concrete such as reflective cracking and depressions. Inspect the seam or joint between adjacent beams for leakage.

Check around scuppers or drain holes and deck fascias for deteriorated concrete.

Check areas exposed to drainage for concrete spalling or cracking. This may occur at the ends of the beams where drainage has seeped through the deck joints.

### **Areas Exposed to Traffic**

For grade crossing structures, check areas of damage caused by collision. This will generally be a corner spall with a few exposed rebars or prestressing strands.



### **Areas Previously Repaired**

Examine areas that have been previously repaired. Determine if the repairs are in place and if they are functioning properly.

### **Other Areas Exposed to External Damage**

- Waterborne debris or ice
- Fire
- Equipment hits
- Displacement of superstructure due to floods, storm surges, etc.

### **General**

Check for efflorescence from cracks and discoloration of the concrete caused by rust stains from the reinforcing steel. In severe cases, the reinforcing steel may become exposed due to spalling. Document the remaining cross section of reinforcing steel since section loss will decrease live load capacity.

### **Camber**

Using a string line, check for horizontal alignment and vertical camber changes from the as-built condition of the prestressed double tee beams. Signs of downward deflection usually indicate loss of prestress. Signs of excessive upward deflection usually indicate extreme creep and shrinkage.

### **Thermal Effects**

These cracks are caused by non-uniform temperatures between two surfaces of the tee-beam. Cracking will typically be transverse in the thinner regions of the tee-beam and longitudinal near changes in cross section thickness.

## 9.8.5

### **Evaluation**

State and Federal rating guideline systems have been developed to aid in the inspection of concrete superstructures. The two major rating guideline systems currently in use are the FHWA's *Recording and Coding Guide for the Structural Inventory and Appraisal of the Nation's Bridges* used for the National Bridge Inventory (NBI) component condition rating method and the AASHTO *Guide Manual for Bridge Element Inspection for* element level condition state assessment.

### **NBI Component Condition Rating Guidelines**

Using NBI component condition rating guidelines, a one-digit code on the Federal Structure Inventory and Appraisal (SI&A) sheet indicates the condition of the deck and the superstructure. Component condition rating codes range from 9 to 0, where 9 is the best rating possible. See Topic 4.2 (Items 58 and 59) for additional details about NBI component condition rating guidelines.

Consider previous inspection data along with current inspection findings to determine the correct component condition rating.

For prestressed double tees, the deck condition influences the superstructure component condition rating. When the deck component condition rating is 4 or less, the superstructure component condition rating may be reduced if the recorded deck deficiencies reduce its ability to carry applied stresses associated with superstructure moments.

### **Element Level Condition State Assessment**

In an element level condition state assessment of a prestressed double tee beam bridge, possible AASHTO National Bridge Elements (NBEs) and Bridge Management Elements (BMEs) are:

#### **NBE No.**

#### **Description**

#### **Decks/Slabs**

15

Prestressed/Reinforced Concrete Top Flange\*

\* Note that this element designation is used regardless of the type of riding surface

#### **Superstructure**

109

Prestressed Concrete Girder/Beam

#### **BME No.**

#### **Description**

#### **Wearing Surfaces and Protection Systems**

510

Wearing Surface

520

Deck/Slab Protection Systems

521

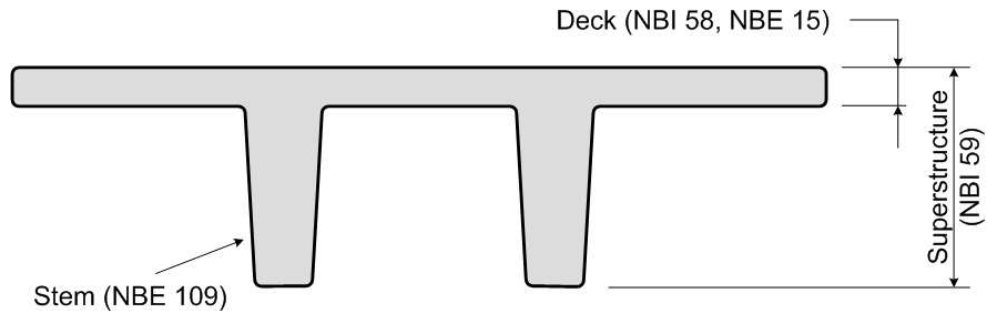
Concrete Protective Coating

The unit quantity for the top flange (deck), wearing surfaces, protection systems and protective coating is square feet. The evaluation of the top flange element is based on the top and bottom surface condition of the top flange (see Figure 9.8.7). The total area is distributed among the four available condition states depending on the extent and severity of the deficiency. The unit quantity for the prestressed double tee beam is feet, and the total length is distributed among the four available condition states depending on the extent and severity of the deficiency. The sum of all condition states equals the total quantity of the National Bridge Element or Bridge Management Element. Condition State 1 is the best possible rating. See the AASHTO *Guide Manual for Bridge Element Inspection* for condition state descriptions.

The following Defect Flags are applicable in the evaluation of prestressed double tee beam superstructures:

<u>Defect Flag No.</u>	<u>Description</u>
358	Concrete Cracking
359	Concrete Efflorescence
362	Superstructure Traffic Impact (load capacity)

See the AASHTO *Guide Manual for Bridge Element Inspection* for the application of Defect Flags.



**Figure 9.8.6** Components/Elements for Evaluation

# Table of Contents

## Chapter 9

---

### Inspection and Evaluation of Concrete Superstructures

9.9	Prestressed I-Beams and Bulb-Tees.....	9.9.1
9.9.1	Introduction.....	9.9.1
9.9.2	Design Characteristics.....	9.9.1
	General.....	9.9.1
	Materials - Strength and Durability .....	9.9.4
	High Performance Concrete.....	9.9.4
	Reactive Powder Concrete .....	9.9.5
	Continuity .....	9.9.5
	Spliced Girders.....	9.9.6
	Composite Action .....	9.9.7
	Primary and Secondary Members .....	9.9.7
	Steel Reinforcement.....	9.9.8
	Primary Reinforcement.....	9.9.8
	High Strength Steel.....	9.9.8
	Mild Steel.....	9.9.8
	Secondary Reinforcement.....	9.9.10
	Composite Strands .....	9.9.10
9.9.3	Overview of Common Deficiencies.....	9.9.10
9.9.4	Inspection Methods and Locations .....	9.9.10
	Methods.....	9.9.10
	Visual.....	9.9.10
	Physical.....	9.9.10
	Advanced Inspection Methods.....	9.9.11
	Locations .....	9.9.11
	Bearing Areas.....	9.9.11
	Shear Zones.....	9.9.13
	Tension Zones.....	9.9.13
	Anchorage for Post-Tensioning System .....	9.9.14
	Secondary Members.....	9.9.14
	Areas Exposed to Drainage.....	9.9.14
	Areas Exposed to Traffic .....	9.9.15
	Areas Previously Repaired.....	9.9.16
	Other Areas Exposed to External Damage .....	9.9.16
	Camber.....	9.9.16
	Post-Tensioned Grout Pockets.....	9.9.16
	Acute Angles on Skewed Bridges.....	9.9.17
	Thermal Effects.....	9.9.17
	Post-Tensioning Tendon Lines .....	9.9.17

9.9.5	Evaluation .....	9.9.17
	NBI Condition Rating Guidelines .....	9.9.17
	Element Level Condition State Assessment.....	9.9.18

# Topic 9.9 Prestressed I-Beams and Bulb-Tees

## 9.9.1

### Introduction

Prestressed I-beams have been used since the 1950's, while prestressed bulb-tee beams have been used since the 1960's. These beam types have proven to be effective because of their material saving shapes. The I or T shape allows a designer to have enough cross-section to place the proper amount of reinforcement while reducing the amount of concrete needed (see Figure 9.9.1).



**Figure 9.9.1** Prestressed I-beam Superstructure

## 9.9.2

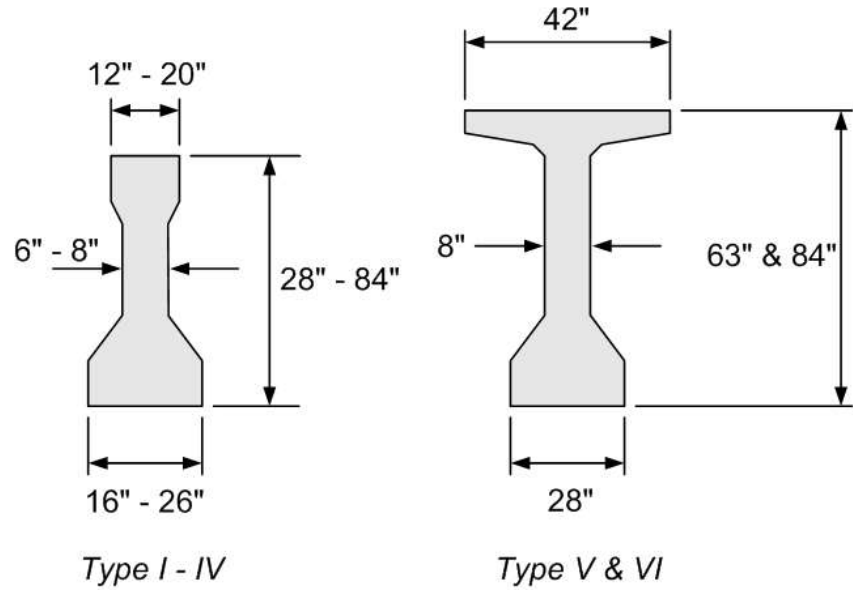
### Design Characteristics

Prestressed I-beams and bulb-tees make economical use of material since most of the concrete mass is located in the top and bottom flanges and away from the neutral axis of the beam.

### General

The most common prestressed concrete I-beam shapes are the AASHTO shapes used by most state highway agencies (see Figures 9.9.2 and 9.9.3). Some highway agencies have also developed variations of the AASHTO I-beam shapes to accommodate their particular needs.

Prestressed I-beams are used in spans ranging from 40 to 200 feet. They are generally most economical at spans from 60 to 160 feet.



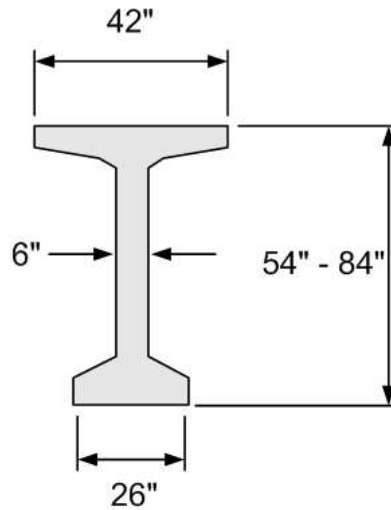
**Figure 9.9.2** AASHTO Cross Sections of Prestressed I-beams



**Figure 9.9.3** AASHTO Prestressed I-beam Bridge

Originally developed from the AASHTO Type V and VI shapes, AASHTO-PCI bulb-tee shapes utilize a smaller cross-section with fewer prestressing strands to achieve comparable span lengths between traditional AASHTO I-beams (see Figures 9.9.4 and 9.9.5). Due to the reduced volume of concrete used in fabrication, bulb-tee beams consequently have reduced material costs, lower shipping weights, and increased stability during transportation. Economical span

lengths range between 80 and 160 feet. When higher strength concrete is used, maximum span lengths can approach 200 feet. Bulb-tee beams are also suited for span continuity using post-tensioning techniques (presented later in this topic). As with AASHTO I-beams, some highway agencies have also developed variations of the AASHTO-PCI bulb-tee shapes to accommodate their particular needs, including New England bulb-tee (NEBT) girders, variable depth bulb-tee beams, and bulb-tees with increased web depths and/or top flange widths.



*AASHTO-PCI Bulb-Tees*

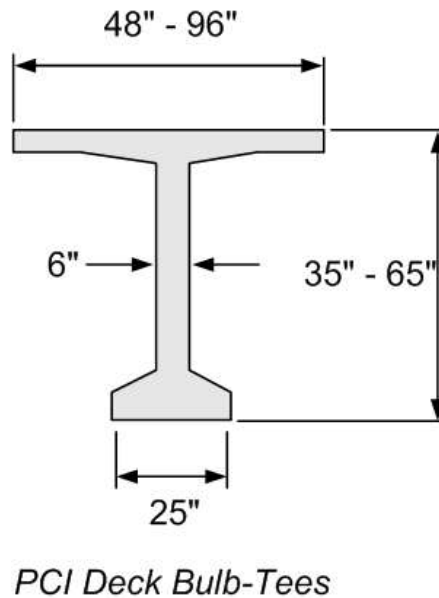
**Figure 9.9.4** Cross Section of AASHTO-PCI Bulb-Tee Beams



**Figure 9.9.5** Placement of an AASHTO-PCI Bulb-Tee Beam



A variation of AASHTO-PCI bulb-tee shapes, deck bulb-tee beams were developed to provide an integral deck-superstructure girder. Using similar geometry as the AASHTO-PCI bulb-tee with the exception of the top flange width (see Figure 9.9.6), these beams have become a viable alternative to adjacent box beam superstructures. Economical span lengths range between 80 and 160, with maximum span lengths of 200 feet depending on the girder depth and top flange width. Some highway agencies have developed variations of the deck bulb-tee girder to accommodate their particular needs, often with increased web depths to achieve maximum span lengths exceeding 200 feet. Deck bulb-tee beams are transversely post-tensioned and/or grouted to allow adjacent units to act integrally or together to carry the live loads. They may also be longitudinally post-tensioned together for splicing and/or continuity, as presented later in this topic.



**Figure 9.9.6** Cross Section of AASHTO-PCI Bulb-Tee Beams

**Materials – Strength and Durability**

Steel tendons with a tensile strength as high as 270 ksi are located in the bottom flange and web (depending on the application). These tendons are used to induce compression across the entire section of the beam prior to and during application of live load. The result is a crack free beam when subjected to live load (see Topic 6.2.5).

New technology may allow designers to reduce corrosion of prestressing strands. This reduction is made possible by using composite materials in lieu of steel. Carbon or glass fibers are two alternatives to steel prestressing strands that are being researched.

Concrete used is also of higher strength ranging from 4,000 psi to 8,000 psi compressive strength. Concrete with ultimate compressive strengths up to 12,000 psi is available. In addition, concrete has a higher quality due to better control of fabrication conditions in a casting yard.

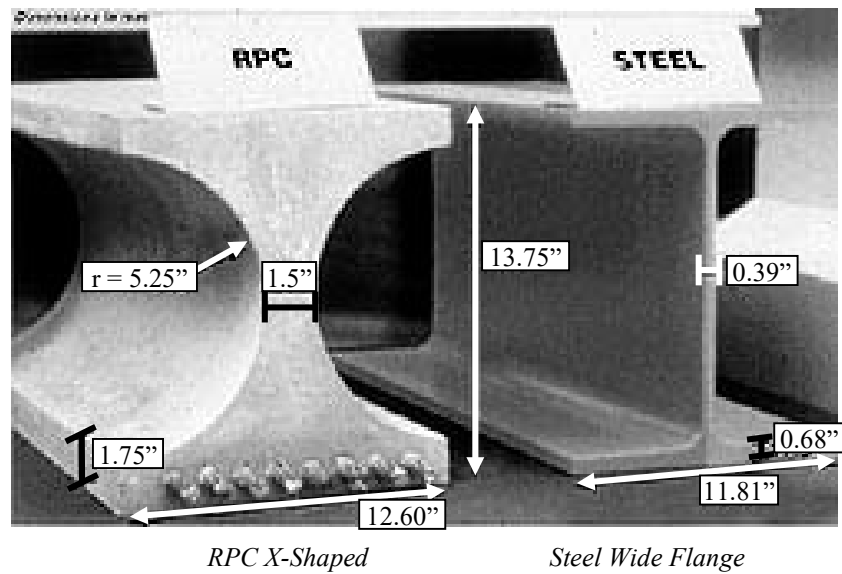
**High Performance Concrete**

High performance concrete (HPC), which is a new type of concrete being used in bridge members, is designed to meet the specific needs of a specific project. The mix design is based on the environmental conditions, strength requirements, and

durability requirements. This type of concrete allows engineers to design smaller, longer, and more durable members with longer life expectancies.

### Reactive Powder Concrete

Reactive Powder Concrete (RPC) prestressed beams can come in an X-shape (see Figure 9.9.7) or other concrete beam shapes. RPC prestressed beams may have an hourglass shape so as to take maximum advantage of RPC properties. Tested prestressed RPC beams are made without any secondary steel reinforcement and can carry the same load as a steel I-beam with virtually the same depth and weight.

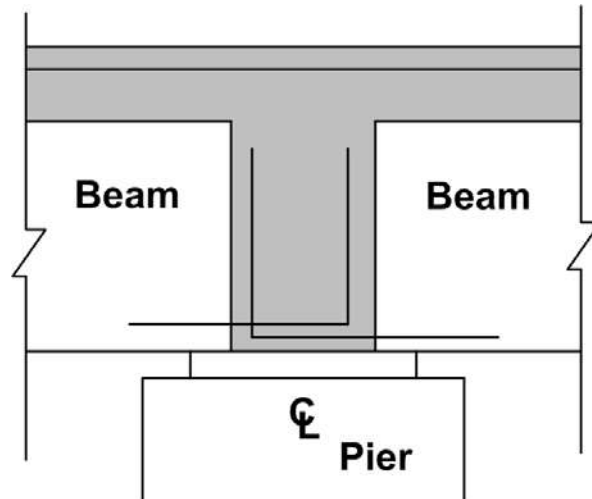


**Figure 9.9.7** Reactive Powder Concrete (RPC) Prestressed X-beam

Reactive Powder Concrete (RPC) creates a better bond between the cement and aggregate. This bond produces a material with a higher density, shear strength, and ductility than normal strength concrete. Silica fume is one of the ingredients in Reactive Powder Concrete that increases the strength. RPC prestressed beams are effective in situations where steel I-beams may be used, but are not effective where conventional strength prestressed concrete I-beams are strong enough.

### Continuity

To increase efficiency in multi-span applications, prestressed I-beams and bulb-tees can be made continuous for live load and/or to eliminate the deck joint. This may be done using a continuous composite action deck and anchorage of mild steel reinforcement in a common end diaphragm (see Figures 9.9.8 and 9.9.9).



**Figure 9.9.8** Continuous Prestressed I-beam Schematic



**Figure 9.9.9** Continuous Prestressed I-Beam Bridge

Continuity has also been accomplished using post-tensioning ducts cast into pretensioned I-beams or bulb-tee beams. Tendons pulled through these ducts across several spans then are stressed for continuity. Cast-in-place concrete diaphragms are framed around the beams at the abutments and piers.

### Spliced Girders

Post-tensioning may also be used to splice I-beam and bulb-tee girder segments together, which are typically pretensioned to resist dead load and transportation stresses. The post-tensioning ducts are typically located in the web, while the bottom flange is pretensioned. This technique allows for span lengths up to 300 feet that can be easily transported in two or three smaller units. Girder splicing may also be used to create multi-span continuous bridges (see Figure 9.9.10).



**Figure 9.9.10** Spliced Bulb-Tees with Haunched Girder Sections Over Piers

**Composite Action**

The deck is secured to and can be made composite with the prestressed beam by the use of extended stirrups which are cast into the I-beam or bulb-tee beam (see Figure 9.9.11).

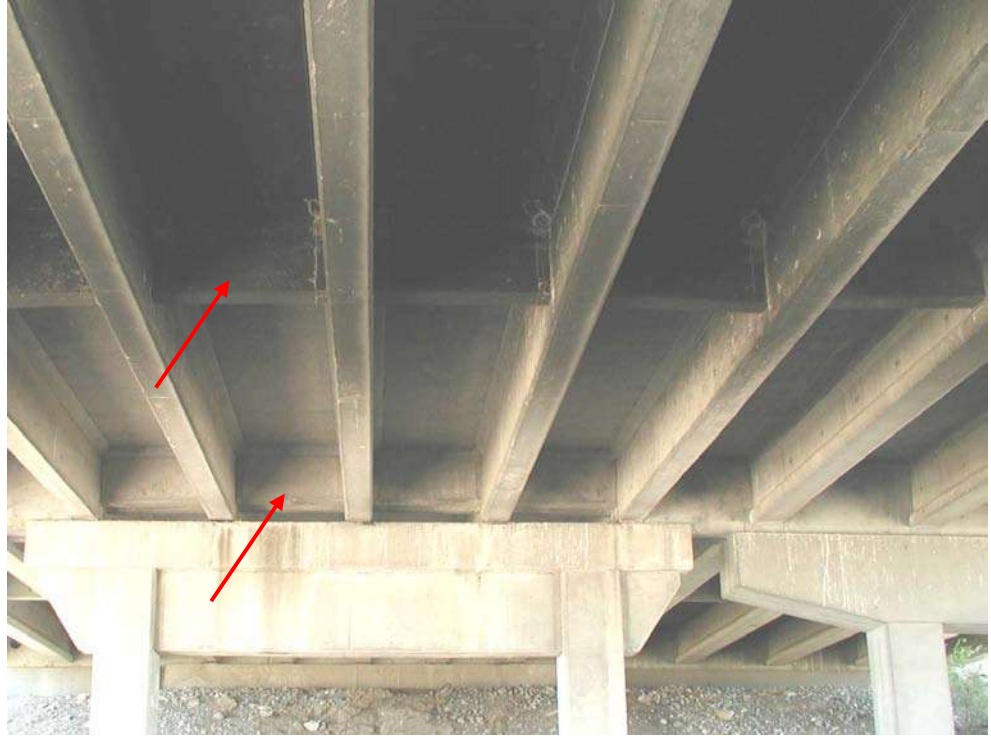
Note that deck bulb-tee beams by themselves (including overlays) are not considered to be composite because the deck (top flange) and beam (web and bottom flange, or "bulb") are constructed of the same material. A composite topping (deck) may be used for some designs.



**Figure 9.9.11** Extended Stirrups to Obtain Composite Action

**Primary and Secondary Members**

The primary members are the prestressed beams. The secondary members are the end diaphragms and the intermediate diaphragms. End diaphragms are usually full depth and located at the abutments or piers. Intermediate diaphragms are partial depth and are used within the span for longer spans (see Figure 9.9.12). Diaphragms are cast-in-place concrete or rolled steel sections and are placed at either the end points, mid points, or third points along the span.



**Figure 9.9.12** Concrete Intermediate and End Diaphragms

## Steel Reinforcement

### Primary Reinforcement

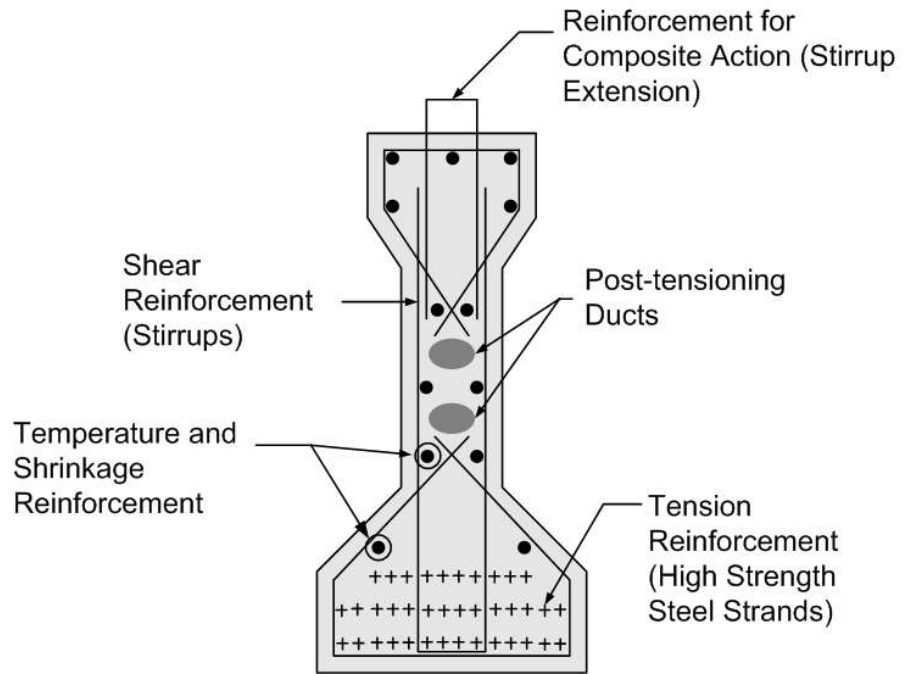
Primary reinforcement consists of main tension steel and shear reinforcement or stirrups.

### High Strength Steel

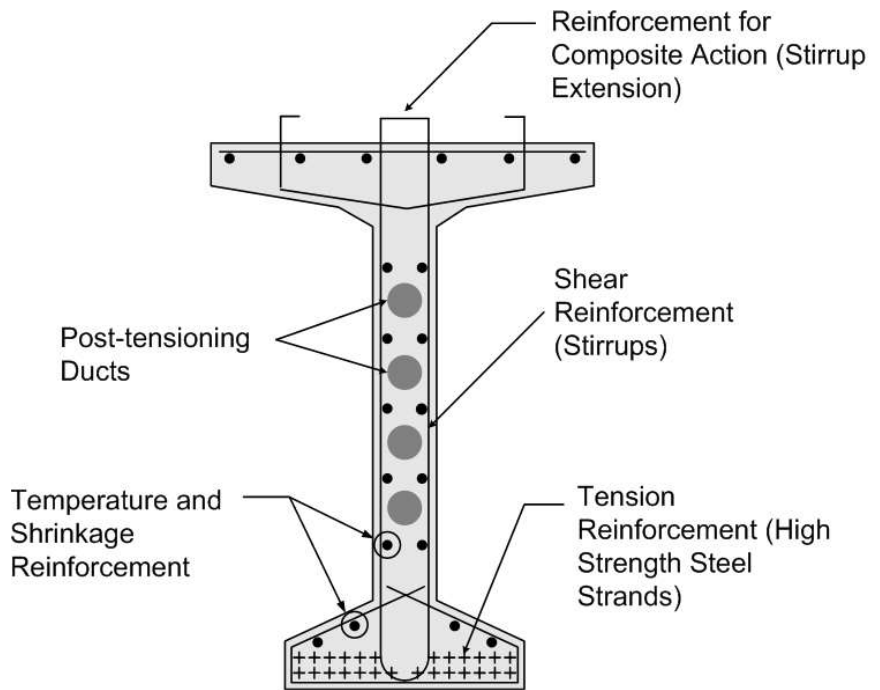
Main tension steel consists of pretensioned high strength prestressing strands or tendons placed symmetrically in the bottom flange and lower portion of the web. Strands are  $3/8$ ,  $7/16$ ,  $1/2$  or  $0.6$  inch in diameter and are generally spaced in a 2 inch grid. In the larger beams, main tension steel can include post-tensioned continuity tendons which are located in ducts cast into the beam web (see Figures 9.9.13 and 9.9.14).

### Mild Steel

Mild steel stirrups are vertical in the beam and located throughout the web at various spacings required by design for shear (see Figures 9.9.13 and 9.9.14). Alternatively, welded wire fabric may be used for shear reinforcement in these beams.



**Figure 9.9.13** Prestressed I-beam Reinforcement



**Figure 9.9.14** Prestressed Bulb-Tee Beam Reinforcement

### Secondary Reinforcement

Secondary reinforcement includes mild steel temperature and shrinkage reinforcement which is longitudinal in the beam. Bulb-tee beams also contain transverse temperature and shrinkage steel in the top flange.

### Composite Strands

Composite strands can be carbon fiber or glass fiber and are fairly new to the bridge prestressing industry. These strands are gaining acceptance due to the low corrosive properties compared to steel strands.

## 9.9.3

### Overview of Common Deficiencies

Common deficiencies that occur on prestressed I-beams and bulb-tees include:

- Cracking (structural, flexure, shear, crack size, nonstructural, crack orientation)
- Scaling
- Delamination
- Spalling
- Chloride contamination
- Freeze-thaw
- Efflorescence
- Alkali silica reactivity (ASR)
- Ettringite formation
- Honeycombs
- Pop-outs
- Wear
- Collision damage
- Abrasion
- Overload damage
- Internal steel corrosion
- Loss of prestress
- Carbonation

Refer to Topic 6.2.6 for a detailed presentation of the properties of concrete, types and causes of concrete deficiencies, and the examination of concrete.

## 9.9.4

### Inspection Methods and Locations

Inspection methods to determine causes of concrete deficiencies are presented in detail in Topic 6.2.8.

#### Methods

##### Visual

The inspection of prestressed concrete I-beams and bulb-tees for surface cracks, spalls, and other deficiencies is primarily a visual activity.

##### Physical

Sounding by hammer can be used to detect delaminated areas. A delaminated area

will have a distinctive hollow "clacking" sound when tapped with a hammer or revealed with a chain drag. A hammer hitting sound concrete will result in a solid "pinging" type sound.

Since prestressed beams are designed to maintain all concrete in compression, cracks are indications of serious problems. Carefully measure any crack with an optical crack gauge or crack comparator card and document the results.

### **Advanced Inspection Methods**

Several advanced methods are available for concrete inspection. Nondestructive methods, described in Topic 15.2.2, include:

- Acoustic wave sonic/ultrasonic velocity measurements
- Electrical methods
- Delamination detection machinery
- Ground-penetrating radar
- Electromagnetic methods
- Pulse velocity
- Flat jack testing
- Impact-echo testing
- Infrared thermography
- Laser ultrasonic testing
- Magnetic field disturbance
- Neutron probe for detection of chlorides
- Nuclear methods
- Pachometer
- Rebound and penetration methods
- Ultrasonic testing
- Smart Concrete
- Carbonation

Other inspection methods or tests for material properties, described in Topic 15.2.3, include:

- Concrete permeability
- Concrete strength
- Endoscopes and videoscopes
- Moisture content
- Petrographic examination
- Reinforcing steel strength
- Chloride test
- Matrix analysis
- ASR evaluation

### **Locations**

### **Bearing Areas**

Check bearing areas for deficiencies such as delaminations, spalls or vertical



cracks (see Figure 9.9.15). Deficiencies may be caused by corrosion of steel due to water leakage or restriction of thermal movement due to a faulty bearing mechanism. Spalling could also be caused by poor quality concrete placement (see Figure 9.9.16).

Check for crushing of flange near the bearing seat.

Check for rust stains which indicate corrosion of steel reinforcement.



**Figure 9.9.15** Bearing Area of a Typical Prestressed I-beam



**Figure 9.9.16** Spalling Due to Poor Concrete Placement

### Shear Zones

Check beam ends and sections over substructure units for transverse cracks on the bottom flange and for diagonal shear cracks in webs. These web cracks will project diagonally upward from the support toward mid-span.

### Tension Zones

Inspect the tension zones of the beams for structural cracks. Since these beams are designed to be in compression, cracking indicates a very serious problem resulting from overloading or loss of prestress. Check for rust stains from cracks, indicating corrosion of steel reinforcement or prestressing tendons.

Check for deteriorated concrete that could cause debonding of the tension reinforcement. This would include spalls, delamination, and cracks with efflorescence.

Check bottom flange for longitudinal cracks that may indicate a deficiency of prestressing steel, insufficient cover, inadequate spacing, unsymmetrical loading in the tendons, or possibly an overloading of the concrete due to use of prestressing strands that are too large.

Check bottom flange at mid-span for flexure cracks due to positive moment (see Figure 9.9.17). These cracks will be quite small and difficult to detect. Use an optical crack gauge or crack comparator card to measure any non-hairline cracks found.

For continuous bridges, check the deck area over the piers for flexure cracks due to negative moment.

Check for exposed tension reinforcement and document section loss on the tendons. Measurable section loss will decrease live load capacity. Exposed prestressing tendons are susceptible to stress corrosion and sudden failure.



**Figure 9.9.17** Flexure Crack

### **Anchorage for Post-Tensioning System**

Check for cracking propagating outward from anchor block or anchor plate on the exposed fascia on the beam webs. Document any cracks found and mark those cracks at the ends to monitor crack growth. Cracks allow moisture to access the transverse post-tensioning rods and accelerate corrosion and section loss of the rods.

Check for kinks, bulges or other deformities in the anchor block or anchor plate. This may be a result of improper installation of the post-tensioning system.

If the grout is visible, note the location and condition of the grout including color differences which may suggest that the initial grouting quality was poor.

### **Secondary Members**

Inspect the end diaphragms for spalling or diagonal cracking (see Figure 9.9.18). This is a possible sign of overstress caused by substructure movement.

Inspect the intermediate diaphragms for cracking and spalling concrete. Flexure and shear cracks may indicate excessive differential movement of the primary superstructure members.



**Figure 9.9.18** Concrete End Diaphragm

### **Areas Exposed to Drainage**

Check around joints, scuppers, inlets or drain holes for leaking water or deterioration of concrete. Check the ends of beams that may be deteriorated due to water leaking through the deck joints (see Figure 9.9.19).



**Figure 9.9.19** Leakage of Water at Joint between Spans

### Areas Exposed to Traffic

Check areas damaged by collision. A significant amount of prestressed concrete bridge deterioration and loss of section is caused by traffic damage. Document the number of exposed and severed strands as well as the loss of concrete section. The loss of concrete due to such an accident is not always serious, unless the bond between the concrete and steel reinforcement is affected (see Figure 9.9.20).



**Figure 9.9.20** Inspectors Evaluating Collision Damage on Prestressed Concrete I-beam

### Areas Previously Repaired

Examine thoroughly any repairs that have been previously made. Determine if repaired areas are sound and functioning properly. Effective repairs such as patching and epoxy injection of cracks are usually limited to protection of exposed tendons and reinforcement (see Figure 9.9.21).



**Figure 9.9.21** Collision Damage Repair on Prestressed Concrete I-Beam. Note Epoxy Injection Ports and Guniting Repair

### Other Areas Exposed to External Damage

- Waterborne debris or ice
- Fire
- Equipment hits
- Displacement of superstructure due to floods, storm surges, etc.

### Camber

Using a string line, check for horizontal alignment and vertical camber changes from the as-built condition of the prestressed beams. Signs of downward deflection usually indicate loss of prestress. Signs of excessive upward deflection usually indicate extreme creep and shrinkage.

### Post-Tensioned Grout Pockets

Check the condition of the lateral post-tensioning grout pockets and visible ends of the post-tensioning rods. Cracked grout or rust stains may indicate a failure of the post-tensioning reinforcement.

### **Acute Angles on Skewed Bridges**

Examine skewed bridges for lateral displacement and cracking of acute corners due to unsymmetrical strand release and insufficient reinforcement.

### **Thermal Effects**

These cracks are caused by non-uniform temperatures between two surfaces of the prestressed beam. Cracking will typically be transverse in the thinner regions of the tee-beam and longitudinal near changes in cross section thickness.

### **Post-tensioning Tendon Lines**

Cracking can occur along any of the lines of post-tensioning tendons. For this reason it is important for the inspector to be aware of where tendons are located in the beam. This cracking may be the result of a bent tendon, a misaligned tendon with insufficient concrete cover or voids around the tendons. Shrinkage of concrete adjacent to large tendons has also caused this type of cracking.

In older post-tensioned bridges, problems due to insufficient grout placement in the conduit around the tendon have been reported. These voided areas can fill with water and the water will accelerate corrosion of the post-tensioning strands. In colder climates, the water may freeze and burst the conduit and surrounding concrete. Radiography and other nondestructive testing methods have been used successfully to locate these voids. These methods are also used to determine if the voids are present during construction of present-day bridges. If voids are found during construction, additional grout is added to eliminate these voids. States such as Florida have revised their polices for grouting materials and methods to eliminate these problems in bridges currently being constructed.

## **9.9.5**

---

### **Evaluation**

State and Federal rating guideline systems have been developed to aid in the inspection of concrete superstructures. The two major rating guideline systems currently in use are the FHWA's *Recording and Coding Guide for the Structural Inventory and Appraisal of the Nation's Bridges* used for the National Bridge Inventory (NBI) component condition rating method and the AASHTO *Guide Manual for Bridge Element Inspection* for element level condition state assessment.

### **NBI Component Condition Rating Guidelines**

Using NBI component condition rating guidelines, a one-digit code on the Federal Structure Inventory and Appraisal (SI&A) sheet indicates the condition of the superstructure. Component condition rating codes range from 9 to 0, where 9 is the best rating possible. See Topic 4.2 (Item 59) for additional details about NBI component condition rating guidelines.

Consider previous inspection data along with current inspection findings to determine the correct component condition rating.

**Element Level Condition State Assessment** In an element level condition state assessment of a prestressed I-beam or bulb-T bridge, possible AASHTO National Bridge Elements (NBEs) and Bridge Management Elements (BMEs) are:

<u>NBE No.</u>	<u>Description</u>
<b>Decks/Slabs</b>	
15	Prestressed/Reinforced Concrete Top Flange* * Note that this element designation is used regardless of the type of riding surface

<b>Superstructure</b>	
109	Prestressed Concrete Girder/Beam

<u>BME No.</u>	<u>Description</u>
<b>Wearing Surfaces and Protection Systems</b>	
510	Wearing Surfaces
520	Deck/Slab Protection Systems
521	Concrete Protective Coating

For bulb-tee beams without a topping slab, wearing surfaces, protection systems and protective coating, the unit quantity is square feet. The evaluation of the top flange element is based on the top and bottom surface condition of the top flange. The total area is distributed among the four available condition states depending on the extent and severity of the deficiency. The quantity for the prestressed I-beam or bulb-tee beam is feet, and the total length is distributed among the four available condition states depending on the extent and severity of the deficiency. The sum of all condition states equals the total quantity of the National Bridge Element or Bridge Management Element. Condition State 1 is the best possible rating. See the AASHTO *Guide Manual for Bridge Element Inspection* for condition state descriptions.

The following Defect Flags are applicable in the evaluation of prestressed I-beam and bulb-tee beam superstructures:

<u>Defect Flag No.</u>	<u>Description</u>
358	Concrete Cracking
359	Concrete Efflorescence
362	Superstructure Traffic Impact (load capacity)

See the AASHTO *Guide Manual for Bridge Element Inspection* for the application of Defect Flags.

# Table of Contents

## Chapter 9

---

### Inspection and Evaluation of Concrete Superstructures

9.10	Prestressed Box Beams .....	9.10.1
9.10.1	Introduction.....	9.10.1
9.10.2	Design Characteristics.....	9.10.1
	General .....	9.10.1
	Design.....	9.10.2
	Simple/Continuous Spans .....	9.10.2
	Composite/Non-composite .....	9.10.2
	Construction .....	9.10.3
	High Performance Concrete .....	9.10.3
	Advantages .....	9.10.3
	Dead Load Reduction .....	9.10.3
	Construction Time Savings.....	9.10.4
	Shallow Depth.....	9.10.4
	Applications.....	9.10.4
	Adjacent Box Beams.....	9.10.4
	Monolithic Action.....	9.10.5
	Spread Box Beams.....	9.10.6
	Primary and Secondary Members .....	9.10.7
	Steel Reinforcement .....	9.10.8
	Primary Reinforcement.....	9.10.8
	High Strength Steel .....	9.10.8
	Mild Steel.....	9.10.9
	Secondary Reinforcement .....	9.10.9
	Fiber Reinforced Polymer Strands .....	9.10.9
9.10.3	Overview of Common Deficiencies.....	9.10.9
9.10.4	Inspection Methods and Locations.....	9.10.10
	Methods.....	9.10.10
	Visual.....	9.10.10
	Physical.....	9.10.10
	Advanced Inspection Methods.....	9.10.10
	Locations .....	9.10.11
	Bearing Areas.....	9.10.11
	Shear Zones.....	9.10.13
	Shear Keys .....	9.10.14
	Anchorage for Post-Tensioning System .....	9.10.14
	Tension Zones.....	9.10.14
	Secondary Members.....	9.10.16
	Joints.....	9.10.16



	Areas Exposed to Drainage.....	9.10.16
	Drain Holes .....	9.10.16
	Areas Exposed to Traffic .....	9.10.17
	Areas Previously Repaired.....	9.10.18
	Acute Angles on Skewed Bridges.....	9.10.18
	Other Areas Exposed to External Damage .....	9.10.18
	Camber.....	9.10.18
	Thermal Effects.....	9.10.18
	General.....	9.10.18
9.10.5	Evaluation .....	9.10.19
	NBI Component Condition Rating Guidelines.....	9.10.19
	Element Level Condition State Assessment.....	9.10.19

# Topic 9.10 Prestressed Box Beams

## 9.10.1

### Introduction

Prestressed box beams are popular and have been used since the early 1950's (see Figure 9.10.1). These precast prestressed members provide advantages from a construction and an economical standpoint by increasing strength while decreasing the dead load.



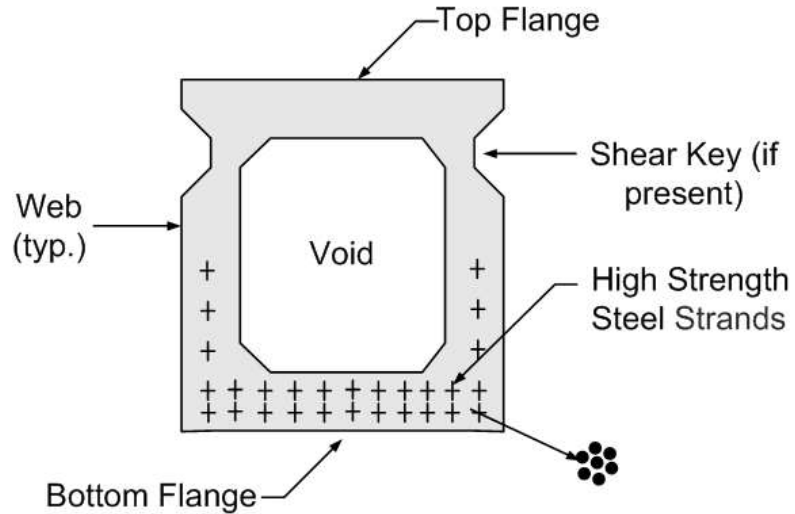
Figure 9.10.1 Typical Box Beam Bridge

## 9.10.2

### Design Characteristics

#### General

Prestressed box beams are constructed having a rectangular cross section with a single rectangular void inside. Many prestressed box beams constructed in the 1950's have single circular voids. The top and bottom slabs act as the beam flanges, while the side walls act as webs. The prestressing reinforcement is typically placed in the bottom flange and into both webs (see Figure 9.10.2).



**Figure 9.10.2** Box Beam Cross-Section

The typical span length for prestressed concrete box beams ranges from 20 to 90 feet depending on the beam size and their spacing.

Prestressed box beams are typically either 36 or 48 inches wide. The depth of a box beam ranges from 27 to 42 inches. Web wall thickness is normally 5 inches but can range from 3 to 6 inches.

## Design

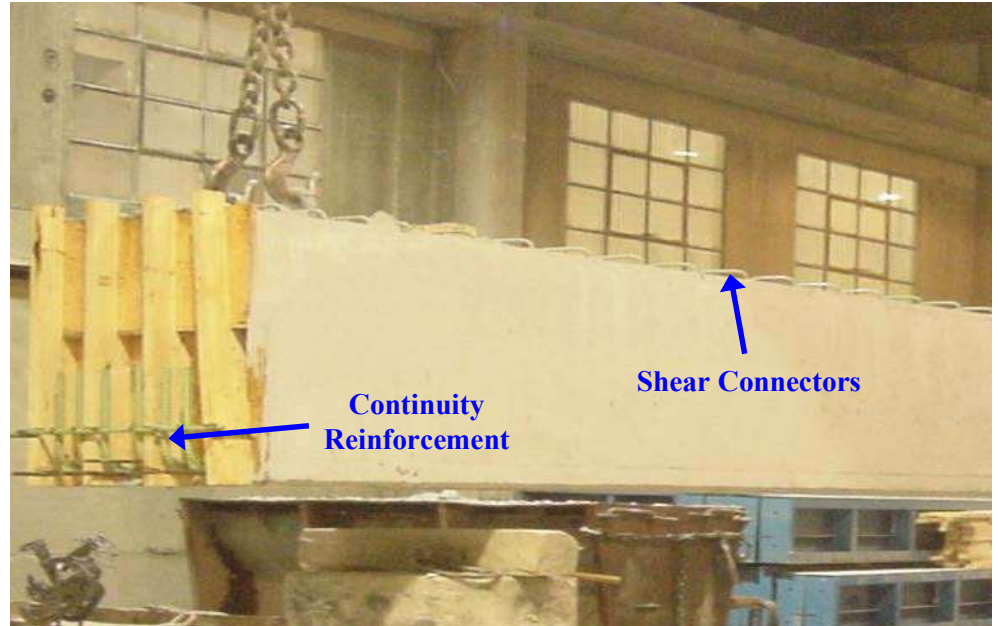
### Simple/Continuous Spans

Prestressed box beams can be simple or continuous spans. In the case of simple spans, the ends of the beams at the piers are not connected together. An expansion joint is placed over the support in the concrete deck and the spans act independently. For continuous spans, the beam-ends from span to span are connected together by means of a cast-in-place concrete end diaphragm over the support. Mild steel reinforcement is placed in this diaphragm area and is spliced with steel reinforcement extending from the prestressed box beams (see Figure 9.10.3). Additional mild steel reinforcement is placed longitudinally in the deck to help achieve continuity. Continuous spans provide advantages such as eliminating deck joints, making a continuous surface for live loads, distributing live loads, and lowering positive moment.

### Composite/Non-composite

Prestressed box beams can be considered composite or not composite. To obtain composite action, some prestressed box beams are constructed with stirrups extending out of the top flange (see Figures 9.10.3 and 9.10.10). These stirrups are engaged when a cast-in-place concrete deck is placed and hardens. Once the concrete deck hardens, the deck becomes composite with the prestressed box beams. This configuration can be considered composite since the compressive strength of the cast-in-place deck is significantly different than the precast prestressed box beams and the deck acts together with the beam to increase superstructure capacity.

Prestressed box beams can also not be considered composite. If the stirrups are not extended into the deck, the prestressed box beams cannot achieve composite action with the deck. Prestressed box beam bridges that do not utilize a concrete deck, but instead allow traffic to travel directly on the top flange or wearing surface, are always considered not to be composite.



**Figure 9.10.3** Box Beams at Fabrication Plant Showing Stirrups Extended as Shear Connectors and Extended Reinforcement for Continuity

### **Construction**

Box beams are constructed similar to I-beams, with high strength steel strands or tendons placed in the bottom flange and lower web area. The strength of the steel strands can be as high as 270 ksi.

Concrete compressive strengths of 4000 to 8000 psi are typically used in prestressed box beams, but concrete with ultimate strengths up to 12,000 psi is available.

### **High Performance Concrete**

High performance concrete (HPC), which is a new type of concrete being used in bridge members, is designed to meet the specific needs of a specific project. The mix design is based on the environmental conditions, strength requirements, and durability requirements. This type of concrete allows engineers to design smaller, longer, and more durable members with longer life expectancies.

### **Advantages**

#### **Dead Load Reduction**

The voided box beam reduces dead load while still providing flanges to resist the design moments and webs to resist the design shears.

### Construction Time Savings

Precast members are cast and cured in a quality controlled casting yard. Because box beams are precast, the construction process takes less time. When construction is properly planned, using precast members allows structure to be erected with less traffic disruption than typical cast-in-place concrete construction.

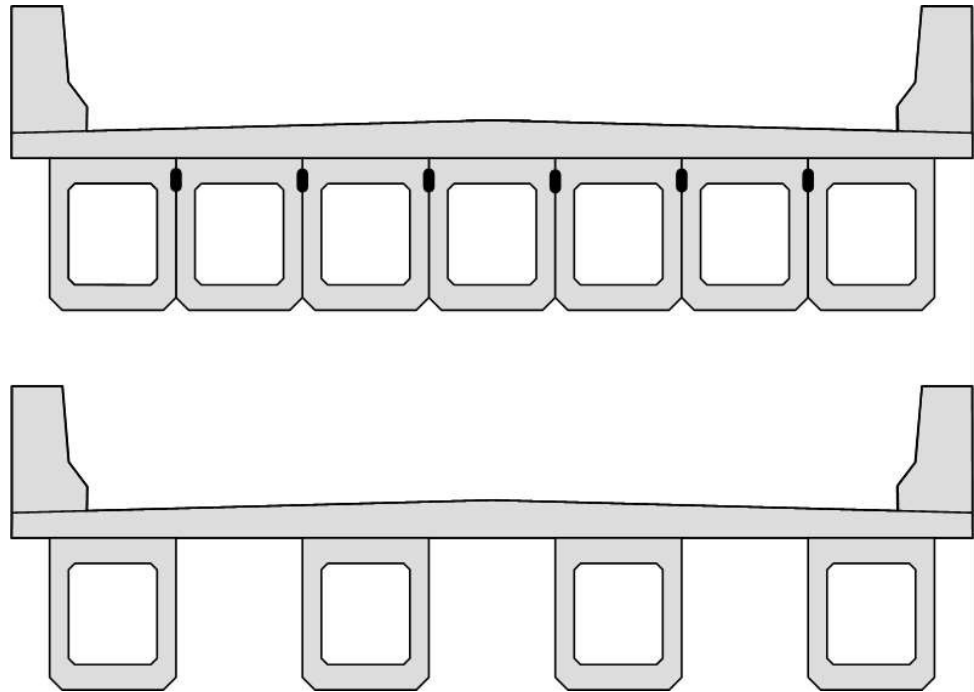
### Shallow Depth

Prestressed box beams are designed with a typical maximum depth of 42 inches. This shallow depth makes box beams viable solutions for field conditions where shallow vertical clearances exist.

### Applications

There are two applications of prestressed box beams (see Figure 9.10.4):

- Adjacent box beams
- Spread box beams



**Figure 9.10.4** Prestressed Box Beam Cross Sections: Adjacent and Spread Box Beams

### Adjacent Box Beams

On an adjacent box beam bridge, the adjacent box beams are placed side by side with no space between them. In some applications, the top flange of each box is exposed and functions as the deck (see Figure 9.10.5). The practical span lengths range from 20 to 130 feet.

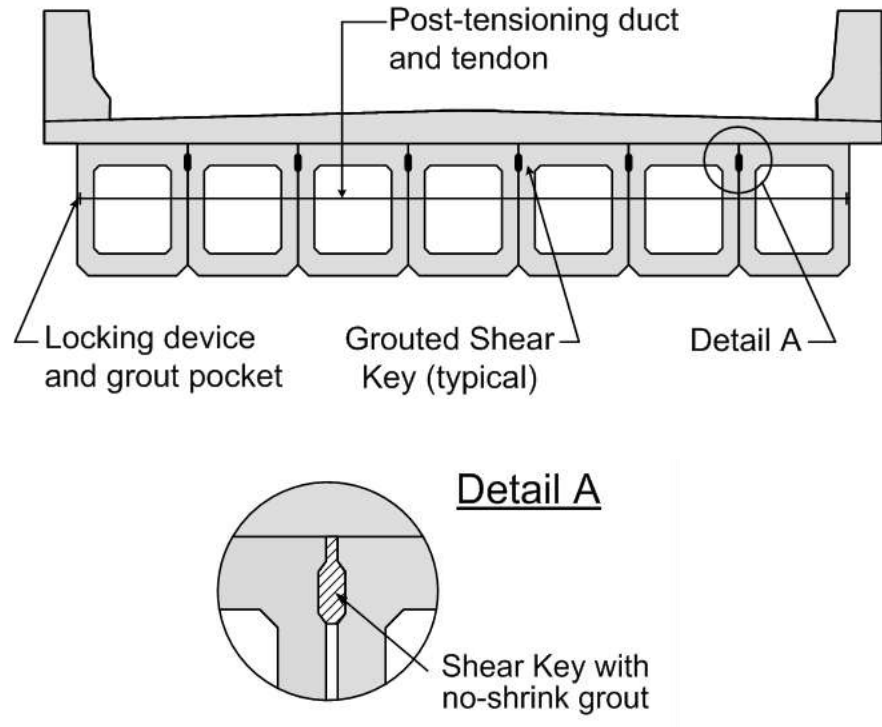


**Figure 9.10.5** Adjacent Box Beams: Top Flanges Acting as the Deck

In modern longer span applications, the deck is typically cast-in-place concrete and composite action with the box beam is achieved after the concrete hardens. For composite decks, stirrups extend above the top of the box to provide the transfer of shear forces. For the majority of shorter spans, nonstructural asphalt overlays are applied and are not considered composite. Sometimes a waterproofing membrane is applied prior to the overlay placement.

#### Monolithic Action

Like precast slab units, adjacent box beams are post tensioned transversely. This is generally done using 145 ksi threaded bars and lock nuts, or 270 ksi strands with locking wedges. Transverse post tensioning combined with grouted shear keys provides for monolithic action (see Figure 9.10.6).



**Figure 9.10.6** Transverse Post-tensioning of an Adjacent Box Beam Bridge

### Spread Box Beams

On a spread box beam bridge, the box beams are usually spaced from 2 to 6 feet apart and typically use a composite cast-in-place concrete deck (see Figure 9.10.7). This application is practical for span lengths from 25 to 85 feet. Stay-in-place forms or removable formwork is used between the box beams to provide support for the concrete prior to curing.



**Figure 9.10.7** Underside of a Typical Spread Box Beam

All modern box beams should have drain holes that are installed in the bottom slab during fabrication to allow any moisture in the void to escape.

**Primary and Secondary Members**

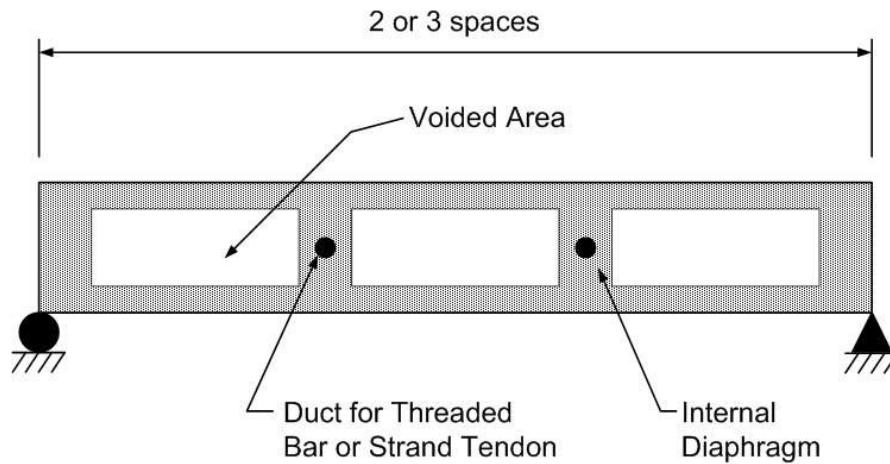
The primary members of box beam bridges are the prestressed concrete box beams. External diaphragms are the only secondary members on box beam bridges, and they are only found on spread box beam bridges (see Figure 9.10.8). The diaphragms may be cast-in-place, precast, or steel and are placed at either the mid points or third points along the span and at the span ends. End diaphragms can provide restraint and act as a backwall. End diaphragms are located at the abutments and piers and can be full or partial depth. Intermediate diaphragms are usually partial depth.

Internal Diaphragms are considered a part of the prestressed box beams and not a secondary member (see Figure 9.10.9).





**Figure 9.10.8** End and Intermediate Diaphragms on a Spread Box Beam Bridge



**Figure 9.10.9** Schematic of Internal Diaphragms

## Steel Reinforcement

### Primary Reinforcement

Primary reinforcement consists of main tension steel and shear reinforcement or stirrups.

### High Strength Steel

Main tension steel consists of high strength pretensioned prestressing strands placed in the flange and lower web of the box beam.

Depending on the age of the structure, the strand size will be 1/4, 3/8, 7/16, 1/2 inch in diameter and spacing is normally 2 inches apart (see Figure 9.10.10). In some newer applications of prestressed box beams using HPC, 0.6-inch strand sizes with a spacing of 2 inches are used to fully implement the increased concrete strengths.

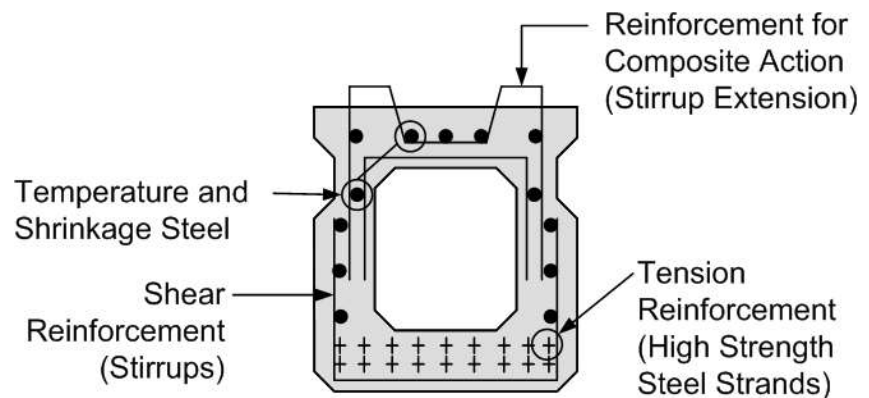
#### Mild Steel

Mild steel stirrups are placed vertically in the web at spacings required by design for shear reinforcement. Mild steel stirrups are more closely spaced near beam ends and typically Grade 60. Older designs may utilize 40 ksi reinforcement.

The current practice is to install the prestressing strands inside the shear stirrups (see Figure 9.10.10). Older designs (1960's) called for the stirrups to be placed between the prestressing strand rows (see Figure 9.10.26).

#### Secondary Reinforcement

Transverse post-tensioning strands through the diaphragms helps maintain monolithic action between the adjacent box beams. Temperature and shrinkage reinforcement consisting of mild steel is placed longitudinal in the beam webs and top flange.



**Figure 9.10.10** Typical Prestressed Box Beam Reinforcement

#### Fiber Reinforced Polymer Strands

Composite strands can be carbon fiber or glass fiber and are fairly new to the bridge prestressing industry. These strands are gaining acceptance due to the low corrosive properties compared to steel strands. Refer to Topic 6.6 for more information.

### 9.10.3

#### Overview of Common Deficiencies

Common deficiencies that occur on prestressed box beams include:

- Cracking (structural, flexure, shear, crack size, nonstructural, crack orientation)
- Scaling
- Delamination
- Spalling

- Chloride contamination
- Freeze-thaw
- Efflorescence
- Alkali silica reactivity (ASR)
- Ettringite formation
- Honeycombs
- Pop-outs
- Wear
- Collision damage
- Abrasion
- Overload damage
- Internal steel corrosion
- Loss of prestress
- Carbonation

Refer to Topic 6.2.6 for a detailed presentation of the properties of concrete, types and causes of concrete deficiencies, and the examination of concrete.

#### **9.10.4**

#### **Inspection Methods and Locations**

Inspection methods to determine other causes of concrete deficiencies are presented in detail in Topic 6.2.8.

#### **Methods**

##### **Visual**

The inspection of prestressed concrete box beams for surface cracks, spalls, downward camber and other deficiencies is primarily a visual activity.

##### **Physical**

Sounding by hammer can be used to detect delaminated areas. A delaminated area will have a distinctive hollow "clacking" sound when tapped with a hammer or revealed with a chain drag. A hammer hitting sound concrete will result in a solid "pinging" type sound. In most cases, a chain drag is used to check the top surface of an exposed top flange.

Since prestressed box beams are designed to limit tensile stresses in concrete to specified thresholds, cracks are indications of serious problems. For this reason, carefully measure any crack with an optical crack gauge or crack comparator card and document the results.

##### **Advanced Inspection Methods**

Several advanced methods are available for concrete inspection. Nondestructive methods, described in Topic 15.2.2, include:

- Acoustic wave sonic/ultrasonic velocity measurements
- Electrical methods

- Delamination detection machinery
- Ground-penetrating radar
- Electromagnetic methods
- Pulse velocity
- Flat jack testing
- Impact-echo testing
- Infrared thermography
- Laser ultrasonic testing
- Magnetic field disturbance
- Neutron probe for detection of chlorides
- Nuclear methods
- Pachometer
- Rebound and penetration methods
- Ultrasonic testing
- Smart Concrete
- Carbonation

Other methods or tests for material properties, described in Topic 15.2.3, include:

- Concrete permeability
- Concrete strength
- Endoscopes and videoscopes
- Moisture content
- Petrographic examination
- Reinforcing steel strength
- Chloride test
- Matrix analysis
- ASR evaluation

## **Locations**

### **Bearing Areas**

Check bearing areas for concrete delaminations, spalls or vertical/horizontal cracks. Spalls and cracks may be caused by corrosion of steel reinforcement due to water leakage or restriction of thermal movement due to a faulty bearing mechanism. Delaminations, spalls and cracks may also be caused by the stresses created at the transfer of the prestressing forces (see Figure 9.10.11).

Check for rust stains, which indicate corrosion of steel reinforcement (see Figure 9.10.12). This corrosion may accelerate due to lack of proper reinforcement bar cover.

Check the bottom of beams for longitudinal cracks originating from the bearing location. These cracks are sometimes caused by the unbalanced transfer of prestress force to the concrete box beam, or by the accumulation of water inside the box, freezing and thawing (see Figure 9.10.13).



**Figure 9.10.11** Spalled Beam Ends with Exposed Prestressing Reinforcement



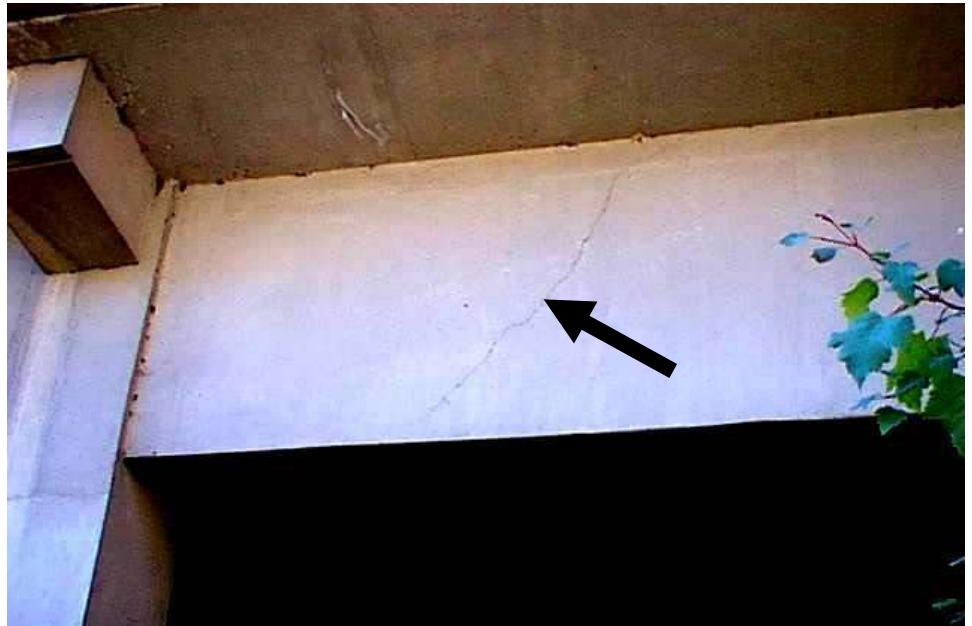
**Figure 9.10.12** Exposed Shear Reinforcement at End of Box Beam



**Figure 9.10.13** Longitudinal Cracks in Bottom Flange of Beam

#### **Shear Zone**

Check beam ends near abutments and piers for diagonal shear cracks in webs. These web cracks will project diagonally upward at approximately a 45 degree angle from the support toward midspan (see Figure 9.10.14). Transverse cracks along the beam bottom at these locations can also be an indication of overstress due to shear.



**Figure 9.10.14** Diagonal Shear Crack in Web of Beam

### **Shear Keys**

In adjacent box beam bridges, check each beam for independent vertical deflection, which may indicate failed shear keys, and lateral deflection on the exterior beams, which may indicate eccentric loading of the exterior beam. Inspect beam joints for signs of leakage between beams, which is indicative of deteriorated shear key grout material.

### **Anchorage for Post-Tensioning System**

Check for cracking propagating outward from anchor block or anchor plate on the exposed fascia on the beam webs. Document any cracks found and mark those cracks at the ends to monitor crack growth. Cracks allow moisture to access the transverse post-tensioning rods and accelerate corrosion and section loss of the rods.

Check for kinks, bulges or other deformities in the anchor block or anchor plate. This may be a result of improper installation of the post-tensioning system.

If the grout is visible, note the location and condition of the grout including color differences which may suggest that the initial grouting quality was poor.

### **Tension Zones**

Inspect the lower portion of the beam, particularly at mid span, for flexure cracks due to negative camber. This indicates a very serious problem resulting from overloading or loss of prestress.

Check for delaminations, spalls and exposed reinforcing steel. Exposed strands fail prematurely due to stress corrosion (see Figures 9.10.15 and 9.10.16).

Check for deteriorated concrete, which could cause debonding of the tension reinforcement. This would include spalls, delaminations, and cracks.

Check bottom flange for longitudinal cracks which may indicate a deficiency of prestressing steel, or possibly an overloading of the concrete due to use of prestressing forces that are too large.

For continuous bridges, check the deck area over the supports for flexure cracks due to negative moment in the beam.



**Figure 9.10.15** Spall and Exposed/Corroded Reinforcement



**Figure 9.10.16** Close-up of Failed Strands due to Corrosion



### **Secondary Members**

Inspect the end diaphragms of spread box beams for delaminations, spalling and cracking. Diagonal cracking is a possible sign of shear failure and can be caused by substructure movement.

Inspect the intermediate diaphragms of spread box beams for delaminations, spalls and cracks. Flexure and shear cracks may indicate excessive differential beam deflection.

### **Joints**

Inspect joints for crushing and movement of the shear keys. The presence of open or loose joints needs to be documented. Areas where the type of construction required closure joints or segments to be poured in place will need close attention. These areas sometimes are regions of tendon anchorages and couplers (if prestressed). The stress concentrations in these areas are very much different than a section away from the anchorages where a distributed stress pattern exists. Additionally, the effects of creep and tendon relaxation are somewhat higher in these regions.

### **Areas Exposed to Drainage**

Examine joints between adjacent box beams for leakage and rust stains. Look for reflective cracking in the traffic surface and differential beam deflection under live load. These problems indicate that the shear key between boxes has been broken and that the boxes are acting independently of each other (see Figure 9.10.17). These problems could also indicate the transverse post-tensioning is not acting as designed. The transverse post-tensioning may have failed due to section loss caused by water and de-icing agents leaking through the shear keys.

Check around scuppers and inlets for leaking water or deterioration of concrete. Check the underside of beam ends for leakage at the expansion joint areas and the fascia of exterior beams.

### **Drain Holes**

Check drain holes for proper function as accumulated water can freeze and crack the beam. Older beams used cardboard to form the voids. The wet cardboard can clog the drain holes.



**Figure 9.10.17** Joint Leakage and Rust Stain

#### **Areas Exposed to Traffic**

Check area damaged by collision. A significant amount of prestressed concrete bridge deterioration and loss of section is due to traffic damage. Document the number of exposed and severed strands as well as the loss of concrete section. The loss of concrete due to such an accident is not always serious, unless the bond between the concrete and steel reinforcement is affected (see Figure 9.10.18).



**Figure 9.10.18** Close-up of Box Beam Collision Damage

### **Areas Previously Repaired**

Examine thoroughly any repairs that have been previously made. Determine if repaired areas are functioning properly. Effective repairs and patching are usually limited to protection of exposed tendons and reinforcement.

### **Acute Angles on Skewed Bridges**

Examine skewed bridges for lateral displacement and cracking of acute corners due to unsymmetrical strand release and insufficient reinforcement.

### **Other Areas Exposed to External Damage**

- Waterborne debris or ice
- Fire
- Equipment hits
- Displacement of superstructure due to floods, storm surges, etc.

### **Camber**

Using a string line, check for horizontal alignment and camber changes from the as-built condition of the prestressed beams. Downward deflection usually indicates loss of prestress or damage to the post-tensioning tendon, preventing cracks from closing. Excessive upward deflection usually indicates extreme initial prestressing forces or shrinkage. Note any changes in camber from previous report that may indicate problems.

### **Thermal Effects**

These cracks are caused by non-uniform temperatures between two surfaces of the beam. Cracking will typically be transverse in the thinner regions of the deck and longitudinal near changes in cross section thickness (if applicable).

### **General**

Note the presence of surface irregularities caused by burlap folds used in the old vacuum curing process. This dates the beam construction to the early 1950's and should alert the inspector to possible deficiencies common in early box beams, such as inadequate or non-existent drainage openings and strand cover.

### 9.10.5

#### **Evaluation**

State and Federal rating guideline systems have been developed to aid in the inspection of concrete superstructures. The two major rating guideline systems currently in use are the FHWA's *Recording and Coding Guide for the Structural Inventory and Appraisal of the Nation's Bridges* used for the National Bridge Inventory (NBI) component condition rating method and the AASHTO *Guide Manual for Bridge Element Inspection* for element level condition state assessment.

#### **NBI Component Condition Rating Guidelines**

Using NBI component condition rating guidelines, a one-digit code on the Federal Structure Inventory and Appraisal (SI&A) sheet indicates the condition of the superstructure. Component condition rating codes range from 9 to 0, where 9 is the best rating possible. See Topic 4.2 (Items 58 and 59) for additional details about NBI component condition rating guidelines for decks and superstructures.

Consider previous inspection data along with current inspection findings to determine the correct component condition rating.

#### **Element Level Condition State Assessment**

In an element level condition state assessment of a prestressed box beam bridge, possible AASHTO National Bridge Elements (NBEs) and Bridge Management Elements (BMEs) are:

<b>NBE No.</b>	<b>Description</b>
<b>Decks/Slabs</b>	
15	Prestressed/Reinforced Concrete Top Flange* * Note that this element designation is used regardless of the type of riding surface
<b>Superstructure</b>	
104	Prestressed Concrete Closed Web/Box Girder
<b>BME No.</b>	<b>Description</b>
<b>Wearing Surfaces and Protection Systems</b>	
520	Deck/Slab Protection Systems
521	Concrete Protective Coating

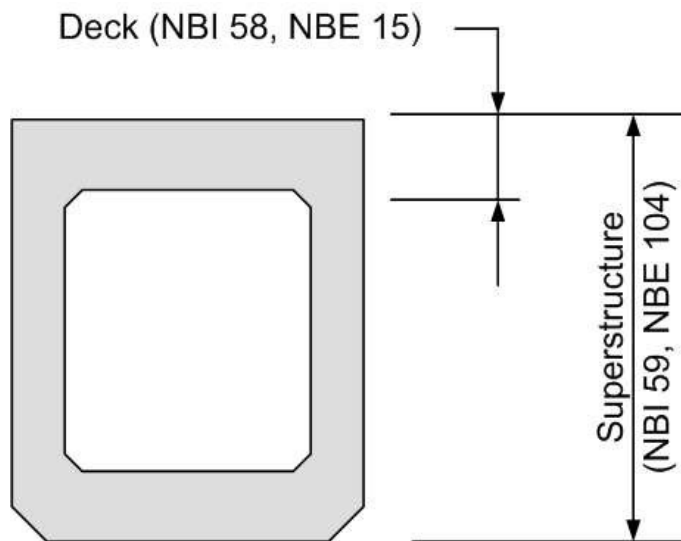
For box beam bridges where the box girder top flange acts as a structural deck (see Figure 9.10.20), NBE No. 15, Prestressed/Reinforced Concrete Top Flange, is used. The unit quantity for this element, along with protection systems and protective coating, is square feet, with the total area distributed among the four available condition states depending on the extent and severity of the deficiency. The unit quantity for the prestressed box beam is feet, and the total length is distributed among the four available condition states depending on the extent and severity of the deficiency. The sum of all condition states must equal the total quantity of the National Bridge Element or Bridge Management Element. Condition State 1 is the best possible rating. See the AASHTO *Guide Manual for*

*Bridge Element Inspection* for condition state descriptions.

The following Defect Flags are applicable in the evaluation of prestressed box beam superstructures:

<u>Defect Flag No.</u>	<u>Description</u>
358	Concrete Cracking
359	Concrete Efflorescence
362	Superstructure Traffic Impact (load capacity)

See the AASHTO *Guide Manual for Bridge Element Inspection* for the application of Defect Flags.



**Figure 9.10.19** Components/Elements for Evaluation

## 9.10.6

### Lessons Learned

#### Lake View Drive Bridge over Interstate I-70

#### General

Adjacent box beam bridges that are not considered composite have unique characteristics that must be considered during inspection. The following case history illustrates the potential for hidden deterioration that can exist in these types of bridges and locations where particular attention must be given. When combined with other factors, these deficiencies can lead to failure. In December 2005, the fascia beam of the Lake View Driver Bridge over Interstate 70 in Pennsylvania failed near mid-span (see Figures 9.10.20 and 9.10.21). The subsequent forensic investigation revealed a number of factors that contributed to the bridge fascia beam failure.



**Figure 9.10.20** View Northeast of I-70 EB from Beneath Span 3



**Figure 9.10.21** View East (Ahead Segments) from SR1014 Above Pier 2

### Superstructure

The Lake View Drive bridge was a two lane, four span structure with Span 2 crossing the westbound lanes and Span 3 crossing the eastbound lanes of I-70. The beam that collapsed was the north elevation fascia beam of Span 3, which is designated as Beam 1. The bridge was constructed in 1960, comprised of eight precast prestressed adjacent box beams (42 inches deep by 48 inches wide) with no independent structural deck. Instead, the non-composite design incorporated a bituminous overlay (approximately 2.5 inches thick) that was placed directly on the beams without a waterproofing membrane. The structure measured 28'-0" curb to curb.

Following the collapse, the remaining superstructure beams (Beams 2 through 8) were visually inspected in the field for broken prestressing strands, structural cracks, joint leakage, and loss of prestress camber. Inspection findings included minor spalling, some exposed prestressing strands, some severed prestressing strands, and collision damage on the underside of Beams 2 and 3 of Span 3. Numerous scrape marks were measured up to 1.5 inches deep in these two beams. Additionally, joint leakage was evident from the bridge barrier, which allowed roadway runoff to travel down the exterior faces of the fascia beams and across the bottom flange. Leakage from the beam joints was also typical between the remaining beams, with the more concentrated leakage between the fascia and first interior beams (Beams 1 and 2, and 8 and 7). Otherwise, all remaining beams were in alignment with no structural cracking, loss of camber, or independent deflection to visually suggest a serious problem.

As per the shop drawings, Beam 1 was a Type 3 Beam with sixty 3/8 inch diameter prestressing strands located in the bottom flange and into the webs.

### Collapsed Beam Findings

Samples were taken from both the failed beam and adjacent beams after the collapse. Material testing confirmed that both the strength of the concrete and prestressing steel were in fact greater than the design values (see Figure 9.10.22). The concrete mixture was also verified to be within specifications. It was determined that all beam construction materials tested did not contribute to the failure of Beam 1.

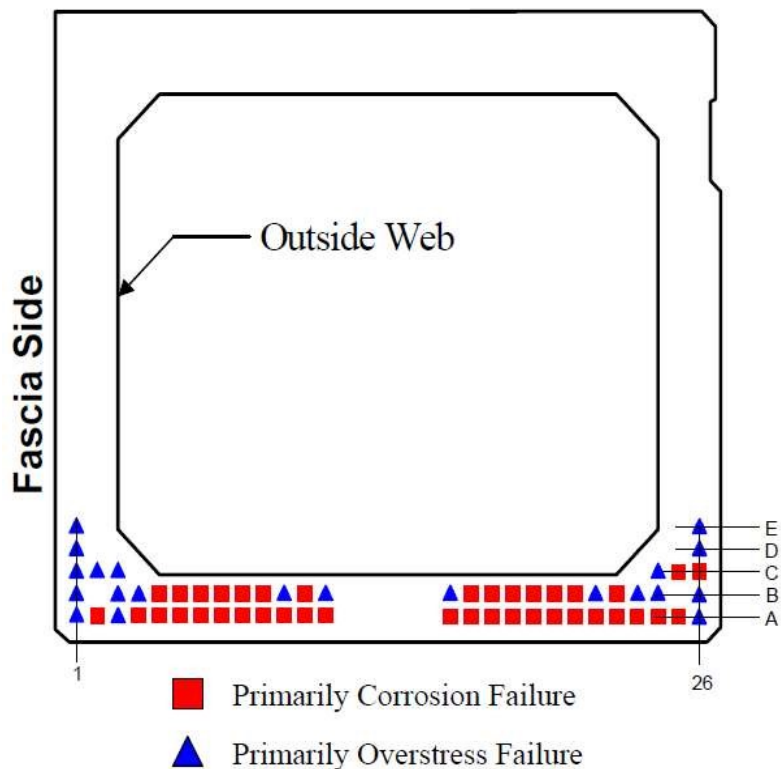
	Design Value	Measured Value	
		Minimum	Maximum
Concrete Strength, $f_c$	5900 psi	6200 psi	8400 psi
Strand Tensile Strength, $F_u$	250 ksi	254 ksi	273 ksi

**Figure 9.10.22** Post-Collapse Material Testing Assessment

Documented collision damage on the fascia beam existed near the point of fracture and resulted in several bottom strands being severed either directly from the collision or due to subsequent corrosion. Spalling was also noted in the vicinity of the collision damage which increased strand exposure to moisture and increased the extent of strand corrosion.

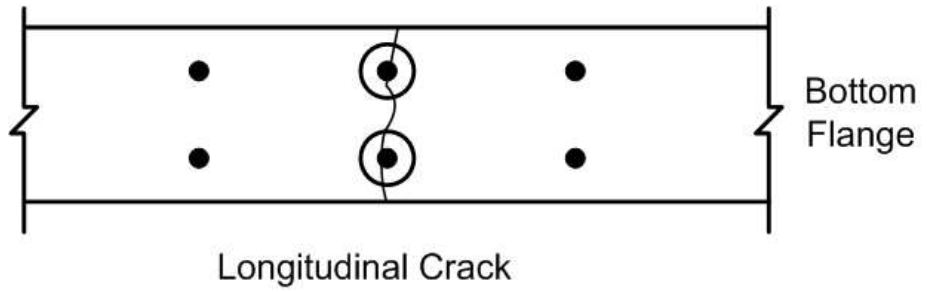
Post-collapse forensic laboratory testing concluded that a total of 39 strands in Beam 1 failed primarily due to environmental corrosion, 19 of which were not visible (see Figure 9.10.23). The sources of moisture contributing to the corrosion of all the strands appeared to be from roadway drainage escaping through a barrier deflection joint near the point of collapse and from the presence of typical moisture spray from traffic passing underneath the bridge. Longitudinal cracks on the bottom flanges allowed a single corroded strand to "transfer" the moisture which caused corrosion to the next row of prestressing strands (see Figure 9.10.24). Corrosion was also simultaneously transferred laterally to adjacent strands by corroding shear reinforcement stirrups (see Figure 9.10.25). This process allowed for corrosion and section loss of strands that were still completely encased in concrete. Wandering cracks induce corrosion of multiple strands in the same way (see Figure 9.10.26).

Strand corrosion resulted in a direct reduction in structural capacity.

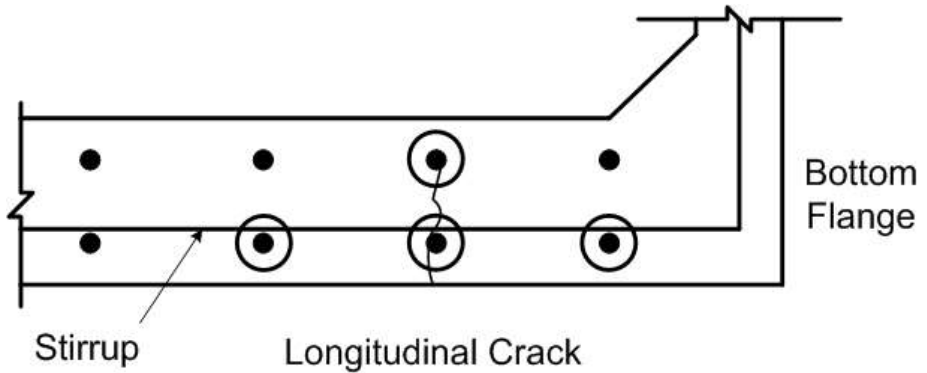


**Figure 9.10.23** Post-Collapse Prestressing Strand Wire Fracture Laboratory Assessment





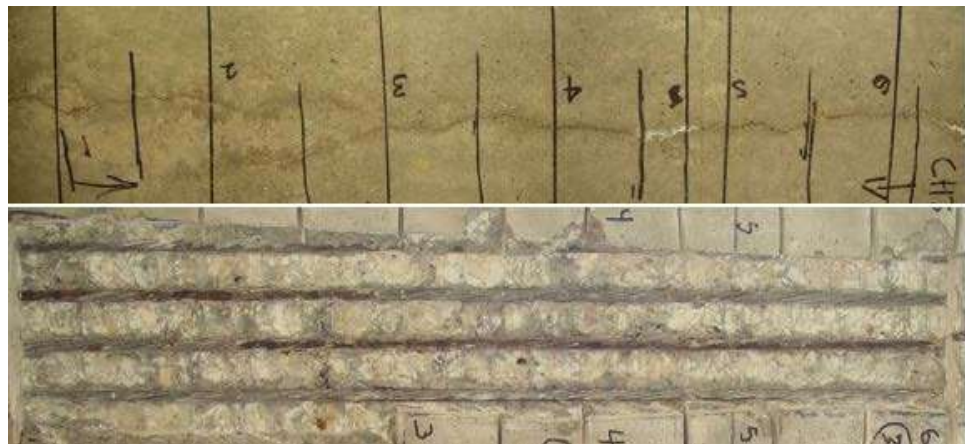
**Figure 9.10.24** Prestressing Strand Corrosion and Section Loss Caused by Moisture Through Longitudinal Cracking



**Figure 9.10.25** Prestressing Strand Corrosion and Section Loss Caused by Moisture Through Longitudinal Cracking and Shear Reinforcement Bars Transferring Moisture to Adjacent Longitudinal Reinforcement

Legend for Figures 9.10.24 and 9.10.25

- ⊙ - Corroded prestressing strand
- - Non-corroded prestressing strand



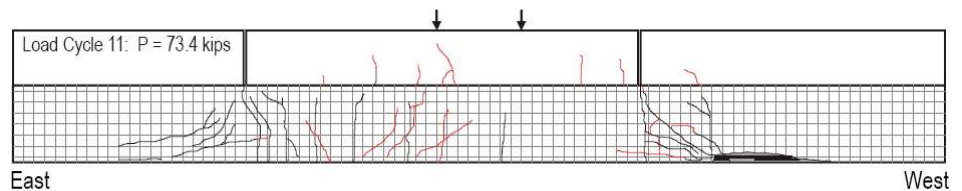
**Figure 9.10.26** Longitudinal Cracks (Top) and Corresponding Corroded Prestressing Strands after Concrete Removed (Bottom)

### Additional Inspection Locations and Requirements

The Lake View Drive Bridge Failure highlights additional inspection locations and requirements for adjacent box beam bridges.

Inspect areas near barrier joints for torsion-shear cracking. These areas on the fascia beams may be subjected to eccentric loading, which was determined to be a contributing factor in the failure of Beam 1. For the Lake View Drive Bridge, with the parapet located 7.25 inches from the outside face of the fascia beam, Beams 1 and 8 rely on shear keys to transform the eccentric dead load into vertical dead load. The vertical dead load is then resisted between multiple beams in the form of primary bending moment. Because the shear key between Beam 1 and 2 had failed, independent beam action was present and the parapet loading was eccentric. The diagonal shear crack in the exterior web of Beam 1 at midspan is indicative of excessive torsion-shear stress (see Figures 9.10.27 and 9.10.28). This overstress was the driving cause of the beam collapse.

Evaluate barriers and barrier connections, looking for water leakage through the barrier deflection joints (see Figure 9.10.29). Because water has high chloride content due to application of years of de-icing agents, leakage into existing cracks will accelerate corrosion of the reinforcing steel and deterioration of the concrete, as with the Lake View Drive Bridge.



**Figure 9.10.27** Laboratory Testing of Torsion-Shear Cracking Near Barrier Joints



**Figure 9.10.28** Cracking Near Barrier Joints



**Figure 9.10. 29** Water Leakage Through Parapet Deflection Joints

#### **Unforeseen Fabrication Problems**

Unforeseen fabrication problems also contributed to the Lake View Drive Bridge failure (see Figure 9.10.30). These problems are listed below:

- The minimum bottom flange thickness was found to be 86% of the design thickness.
- The average concrete cover over the strands was measured 0.87" average compared to 1- 9/16" as noted in the design drawings.
- The minimum wall thickness was measured to be 66% of the design value. It is thought the cardboard formwork shifted during fabrication. The decreased wall thickness reduces shear capacity of the beam.
- Lateral post-tensioning tie rods were heavily corroded, and there was poor consolidation of grout in the shear keys.
- Vent holes for curing in top flange were left open, and drain holes in the bottom flange were closed, resulting in an accumulation of moisture and even standing water.

Inspectors could not determine these fabrication problems without extensive use of nondestructive evaluation testing equipment. Prestressed concrete beams are currently constructed to tighter tolerances than 1960 (the date of fabrication for the beams in the Lake View Drive Bridge).



**Figure 9.10.30** Unforeseen Fabrication Problems

### **Summary**

In response to the findings, a revised and more detailed set of inspection methods and condition rating assessment guidelines are now followed for all adjacent box beam bridges that are not considered composite.

Focus on the barrier joint location for the presence of torsion and shear cracking. The torsion contribution comes from the eccentric loading of the barrier on the exterior beam and the loss of shear key resistance with the adjacent first interior beam.

Pay particular attention to the examination of fascia beams for present of cracking at drainage locations where runoff can come in contact with the sides and bottoms of the beams (see Figures 9.10.27, 9.10.28, and 9.10.29).

The effects of any longitudinal cracking in bottom strand locations, likely resulting in corrosion of non-visible strands including those above the bottom row, will now be accounted for in the condition assessment of adjacent box beam bridges that not considered to be composite.

This page left intentionally blank.

# Table of Contents

## Chapter 9

---

### Inspection and Evaluation of Concrete Superstructures

9.11 Concrete Box Girders.....	9.11.1
9.11.1 Introduction.....	9.11.1
9.11.2 Design Characteristics.....	9.11.2
Concrete Box Girder.....	9.11.2
Construction Methods.....	9.11.2
High Level Casting.....	9.11.3
At-grade Casting.....	9.11.4
Primary Members.....	9.11.5
Steel Reinforcement.....	9.11.5
Segmental Box Girder.....	9.11.7
Segment Configurations.....	9.11.9
Segmental Classification.....	9.11.10
Cast-in-Place.....	9.11.10
Precast.....	9.11.11
Construction Methods.....	9.11.12
Balanced Cantilever.....	9.11.12
Span-by-span Construction.....	9.11.13
Progressive Placement Construction.....	9.11.15
Incremental Launching Construction.....	9.11.16
9.11.3 Overview of Common Deficiencies.....	9.11.17
9.11.4 Inspection Methods and Locations.....	9.11.18
Methods.....	9.11.18
Visual.....	9.11.18
Physical.....	9.11.18
Advanced Inspection Methods.....	9.11.18
Locations-Concrete Box Girder.....	9.11.19
Bearing Areas.....	9.11.19
Shear Zones.....	9.11.20
Tension Zones.....	9.11.21
Anchor Blocks.....	9.11.23
Deviation Blocks.....	9.11.23
Internal Diaphragms.....	9.11.25
Secondary Members.....	9.11.25
Areas Exposed to Drainage.....	9.11.25
Drain Holes.....	9.11.25
Areas Exposed to Traffic.....	9.11.26
Areas Previously Repaired.....	9.11.26
Other Areas Exposed to External Damage.....	9.11.26

Post-Tensioned Grout Pockets .....	9.11.27
Camber .....	9.11.27
Miscellaneous Areas.....	9.11.27
Locations-Segmental Box Girder.....	9.11.31
Bearing Areas .....	9.11.31
Shear and Tension Zones.....	9.11.32
Anchor Blocks.....	9.11.32
Deviation Blocks .....	9.11.33
Secondary Members .....	9.11.33
Joints.....	9.11.33
Internal Diaphragms .....	9.11.35
Areas Exposed to Drainage .....	9.11.36
Drain Holes.....	9.11.36
Areas Exposed to Traffic.....	9.11.36
Areas Previously Repaired .....	9.11.36
Other Areas Exposed to External Damage .....	9.11.36
Post-Tensioned Grout Pockets .....	9.11.36
Camber .....	9.11.36
Miscellaneous Areas.....	9.11.36
9.11.5 Evaluation .....	9.11.37
NBI Component Condition Rating Guidelines.....	9.11.37
Element Level Condition State Assessment.....	9.11.37

# Topic 9.11 Concrete Box Girders

## 9.11.1

### Introduction

The popularity of box girder design is increasing. A trapezoidal box shape with cantilevered top flange extensions combines mild steel reinforcement and high strength post-tensioning tendons into a cross section capable of accommodating an entire roadway width. Both segmental and monolithic box girders are in service.

Older box girder bridges can be cast-in-place concrete with conventional steel reinforcement and post-tensioning reinforcement. Current designs for concrete box girders typically use post-tensioning (see Figures 9.11.1, 9.11.2 and 9.11.3).



**Figure 9.11.1** Segmental Precast Concrete Box Girder Bridge



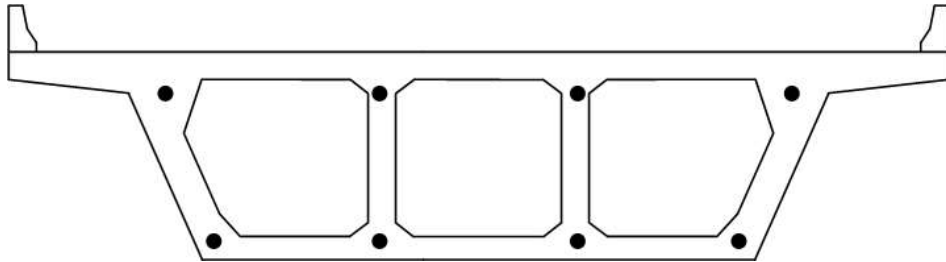


**Figure 9.11.2** Cast-in-place Concrete Box Girder Bridge

## 9.11.2

### Design Characteristics

**Concrete Box Girder** For wide roadways, the box portion generally has internal webs and is referred to as a multi-cell box girder (see Figure 9.11.3). Concrete box girder bridges are designed as either single span or continuous multi-span structures. Spans can have a straight or curved alignment and are generally in excess of 150 feet (see Figure 9.11.4).



**Figure 9.11.3** Multi-cell Girder: Post Tensioned

### Construction Methods

The two basic construction techniques used for cast-in-place monolithic box girders are high level casting and at-grade casting.

The following description applies to monolithic box girder construction only. A detailed description of segmental concrete bridges appears later in this Topic.



**Figure 9.11.4** Cast-in-place Concrete Box Girder Bridge

#### High Level Casting

The high level casting method employs formwork supported by falsework. This technique is used when the structure must cross an existing feature, such as a roadway, railway, or waterway (see Figure 9.11.5).



**Figure 9.11.5** High Level Casting Formwork on Falsework

### At-grade Casting

The at-grade casting method employs formwork supported by fill material or the existing ground. When the construction is complete, the earth beneath the bridge is removed. This technique is used when the structure is crossing, or is part of a new highway system or interchange (see Figures 9.11.6 and 9.11.7).



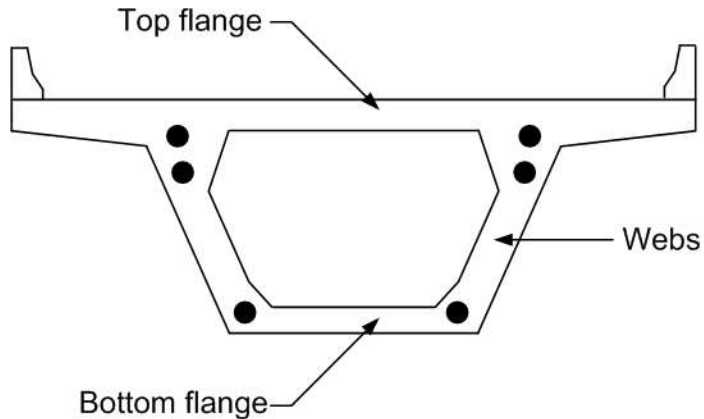
**Figure 9.11.6** At-grade Formwork with Post-tensioning Ducts



**Figure 9.11.7** At-grade Casting – After Supporting Earth Removed

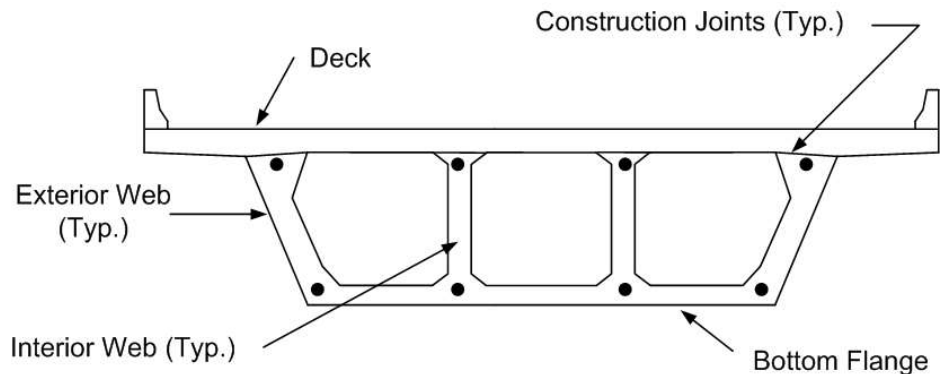
### Primary Members

For box girder structures, the primary member is the box girder. When a single-cell box girder design is used, the top flange or deck, the bottom flange, and both webs are all primary elements of the box girder (see Figure 9.11.8). The top flange is considered an integral deck component/element.



**Figure 9.11.8** Basic Components/Elements of a Concrete Box Girder

In some multi-cell box girder applications, the top flange or deck must be removable for future replacement. The top flange in these cases functions similarly to an integral deck and is in fact considered a separate deck component/element. Most exterior webs are designed for higher stress levels than interior webs. The interior webs of the box also play a significant role in the box girder structure since they help support the deck (see Figure 9.11.9).



**Figure 9.11.9** Replaceable Deck on a Multiple Cell Cast-in-place Box Girder

### Steel Reinforcement

Box girder structures use a combination of primary mild steel reinforcement and high strength post-tensioning steel tendons to resist tension and shear forces (see Figure 9.11.10).

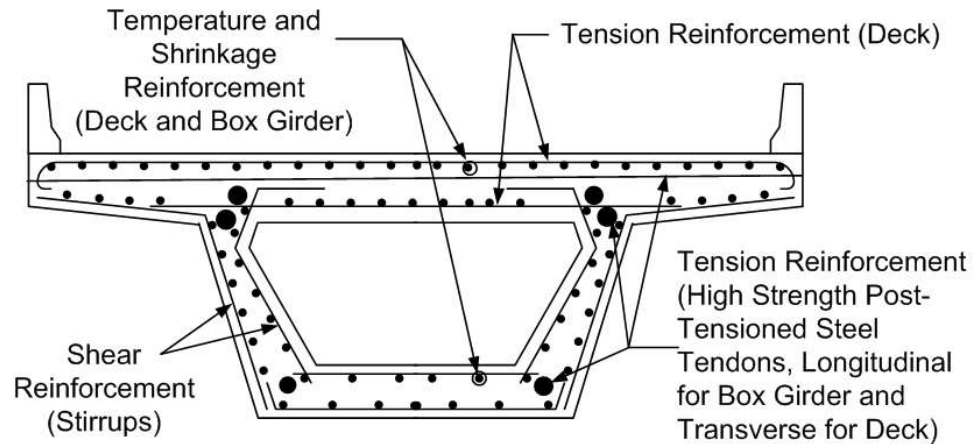
Tension reinforcement to resist flexure is provided in the top and bottom flanges of the box girder as necessary (bottom flange at midspan in areas of positive moment and top

flange over supports in areas of negative moment). However, because of the design span lengths, mild steel reinforcement does not have sufficient strength to resist all of the tension forces. To reduce these tensile stresses to acceptable levels, prestressing of the concrete is introduced through post-tensioning. Galvanized metal and polyethylene ducts are placed in the forms at the desired location of the tendons. When the concrete has cured to an acceptable strength level, the tendons are installed in the ducts, tensioned, and then grouted (see Figure 9.11.6).

The top flanges or decks of precast or cast-in-place segmental boxes are often transversely post-tensioned. The multi-strand tendons in the webs and flanges are grouted after post-tensioning. The tendons anchor in block-outs in the edges of top slab cantilever wings. For precast units, the top flange tendons are generally tensioned and grouted in the casting yard. Wide bridges may have parallel twin boxes transversely post-tensioned. When this is the case, only about one-half of the transverse post-tensioning is stressed before shipment. The remainder of the post-tensioning is placed through ducts in adjacent box girders and the closure strip and stressed across the entire width of the bridge.

Conventional reinforcement bar stirrups in the web are provided to resist standard beam action shear. For curved girder applications, torsional shear reinforcement is sometimes required. This reinforcement is provided in the form of additional stirrups.

The secondary (temperature and shrinkage) reinforcing steel is oriented longitudinally in the deck and webs and flanges in the box girder. The primary and secondary reinforcing steel for the deck portion of the girder is the same as for a standard concrete deck (see Figure 9.11.10).

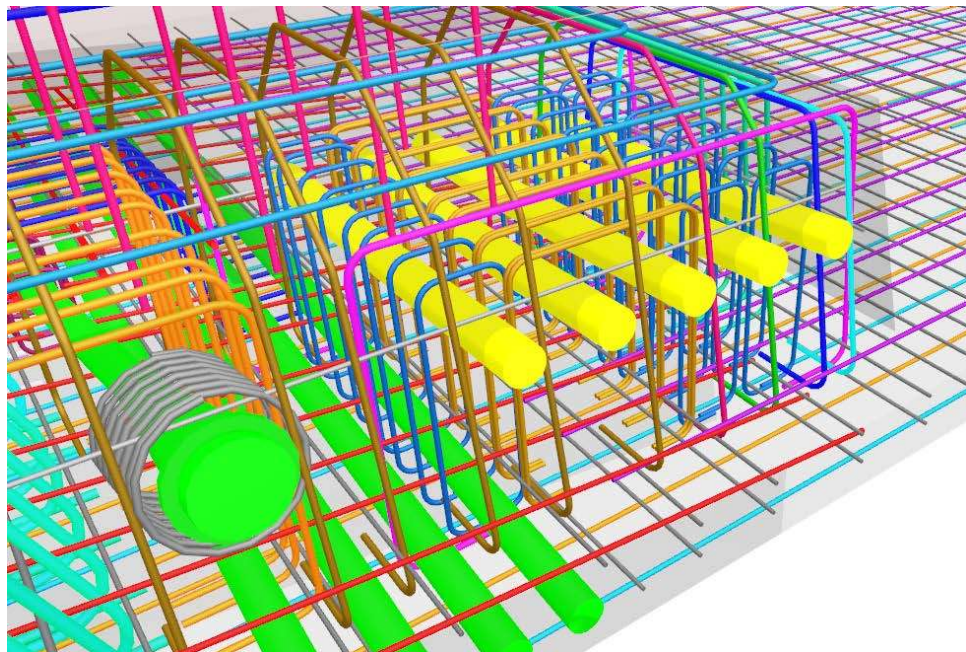


**Figure 9.11.10** Primary and Secondary Reinforcement in a Concrete Box Girder

Special "confinement" reinforcement is also required at the anchorage locations to prevent cracking due to the large transfer of force to the surrounding concrete (see Figures 9.11.11 and 9.11.12).



**Figure 9.11.11** Post-tensioning Spiral Anchorage Reinforcement Prior to Concrete Placement



**Figure 9.11.12** Three-Dimensional Model Illustrating Confinement Reinforcement Around Anchorage and Deviation Blocks (Click to Open Interactive Model)

### **Segmental Box Girder**

Segmental box girders are similar to concrete box girders presented earlier in this subtopic. The preceding portion of the subtopic highlights the similarities and especially the differences with concrete box girders.

Many current box girders are built using segmental construction. A segmental concrete bridge is fabricated piece by piece. These pieces, or segments, are post-tensioned

together during the construction of the bridge (see Figures 9.11.14 and 9.11.15). The superstructure can be constructed of precast concrete or cast-in-place concrete segments. Several characteristics are common to most segmental bridges:

- Used for medium and long span bridges (spans can be as short as 130 feet, see Figure 9.11.14)
- Used when falsework is undesirable or cost-prohibitive such as bridges over steep terrain or environmentally sensitive areas
- For most bridges, each segment is the full width and depth of the bridge; for very wide decks, many segmental box girders may consist of two-cell boxes or adjacent single boxes with a longitudinal cast-in-place concrete closure pour (see Figure 9.11.13)
- The length of the segments is determined by the construction methods, equipment available to the contractor, and local weight restrictions to transport the segments to the project site.
- Each new segment will be supported from previously erected segments during construction



**Figure 9.11.13** Adjacent Single Cell Boxes with Closure Pour



**Figure 9.11.14** Segmental Concrete Bridge



**Figure 9.11.15** Close-up of Box Girder Segments

### **Segment Configurations**

The majority of concrete segmental bridges use a box girder configuration (see Figure 9.11.16). The box girder is preferred due to the following:

- The top flange can be used as the roadway traffic surface (deck)
- The wide top and bottom flanges provide large areas to resist compression
- The box shape provides excellent torsional rigidity
- The box shape lends itself well to horizontally curved alignments



The typical box girder section will have the following elements:

- Top deck/flange
- Bottom flange
- Web walls
- Interior web walls (multi-cell)

Single box girder segments are usually used, although spread multiple boxes can be used if they are connected together by external diaphragms.

### Segmental Classification

Individual segments can either be cast-in-place or precast concrete.



**Figure 9.11.16** Box Girder Segment

#### Cast-in-Place

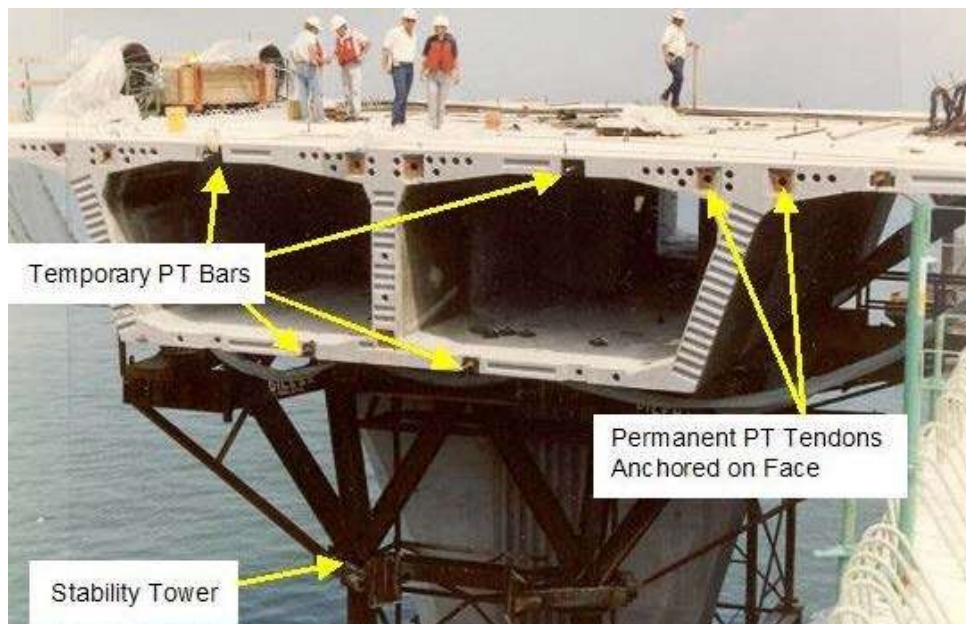
Cast-in-place segmental construction is generally performed by supporting the segment formwork from the previous cast segment. Reinforcement and concrete is placed and the segment is cured. When the newly cast segment has reached sufficient strength, it is post-tensioned to the previous cast segments (see Figure 9.11.17). This process proceeds until the bridge is completed.



**Figure 9.11.17** Cast-in-place Box Girder Segment

#### Precast

Precast segmental construction is performed by casting the individual segments prior to erecting them. The actual casting can take place near the project location or at an off-site fabrication plant. Once the precast segment is positioned adjacent to the previous placed segment, it is post-tensioned in the same manner as the cast-in-place segment previously mentioned. This process also repeats itself until the bridge is completed (see Figure 9.11.18).



**Figure 9.11.18** Box Girder Segment During Construction with Temporary and Permanent Post-Tensioning (PT) Bars.

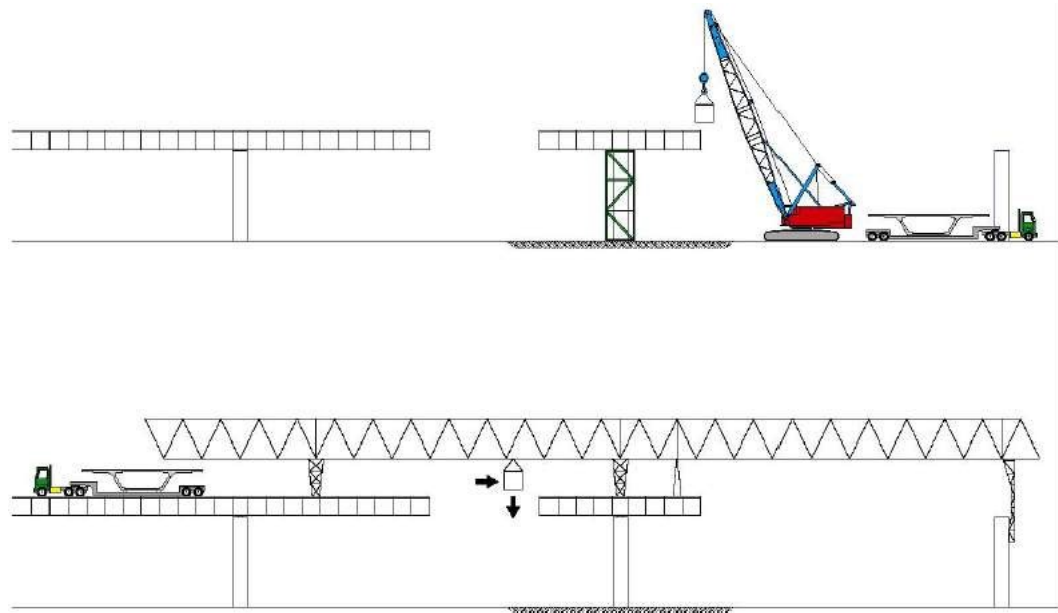
Precast construction lends itself well to repetitive operations and associated efficiencies. Fabrication plant operations also tend to offer higher degrees of quality control than field operations associated with cast-in-place construction. Precast construction must be monitored and controlled to ensure the proper fit in the field with regards to vertical and horizontal alignment. In order to control this situation, match casting is usually employed. Match casting utilizes the previous segment as part of the formwork for the next segment to ensure proper mating segments. Epoxy bonding adhesive is applied to the match-cast joints during initial erection.

Cast-in-place construction frequently does not benefit from the efficiencies of precast construction but does have the advantage of relatively easy field adjustments for controlling line and grade of alignment.

### Construction Methods

#### Balanced Cantilever

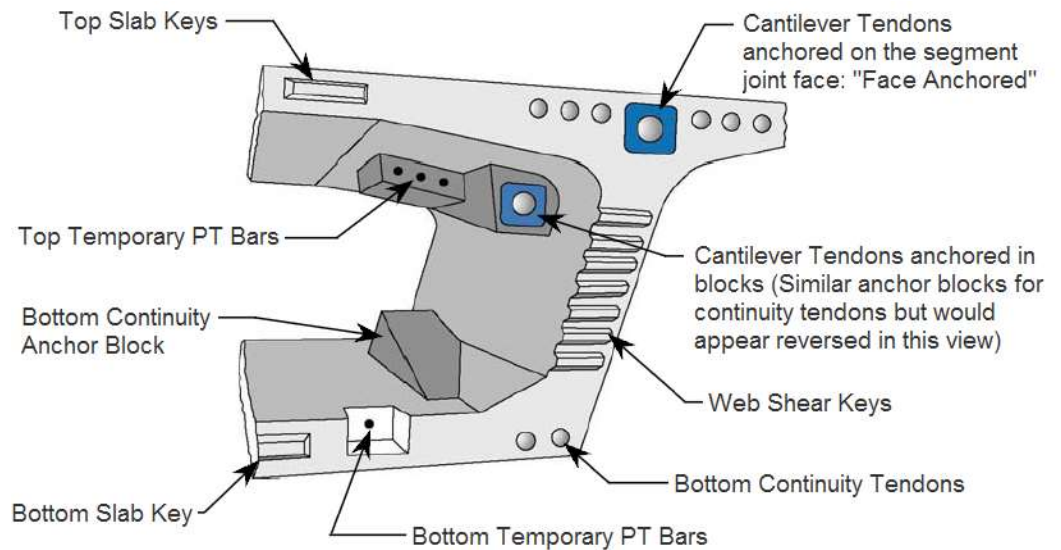
This form of construction requires individual segments to be placed symmetrically about a pier. As the segments are alternately placed about the pier, the bending moments induced at the pier by the cantilever segments tend to balance each other. Once the mid-span is reached, a closure segment is cast together with the previously erected half-span from the adjacent pier. This method is repeated until all the spans have been erected (see Figures 9.11.19, 9.11.20 and 9.11.21). Both cast-in-place and precast construction is suitable for balanced cantilever construction.



**Figure 9.11.19** Two Balanced Cantilever Methods - Using Cranes with Stability Towers At Each Pier and Using An Overhead Launching Gantry



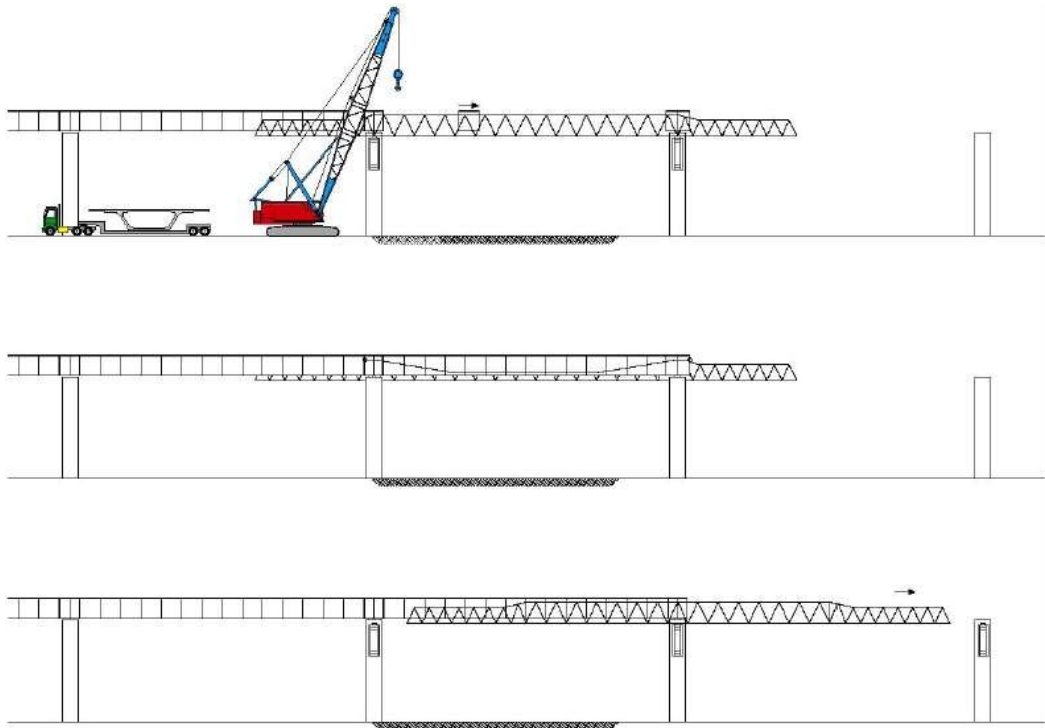
**Figure 9.11.20** Balanced Cantilever Construction Using An Overhead Launching Gantry



**Figure 9.11.21** Typical Features of Precast Cantilever Box Girder Segments

### Span-by-span Construction

This form of construction may require a temporary steel erection truss or falsework, which spans from one pier to another. The erection truss provides temporary support of the individual segments until they are positioned and post-tensioned into their final configuration. This type of construction allows a total span to be erected at one time. Once the span has been completed the erection truss is removed and repositioned on the next adjacent span. This method is repeated until all the spans have been erected (see Figures 9.11.22 and 9.11.23).



**Figure 9.11.22** Span-by-Span Construction (with Erection Truss)



**Figure 9.11.23** Span-by-span Construction (with Erection Truss)

The entire span may also be assembled or cast on the ground, or on a floating barge. The span is raised to final position with cranes or lifting jacks and made continuous with the previously placed pier segments by closure pours and longitudinal post-tensioning. Both cast-in-place and precast construction is suitable for this form of construction (see Figure 9.11.24).



**Figure 9.11.24** Span-by-span Total Span Erection (Lifting)

#### Progressive Placement Construction

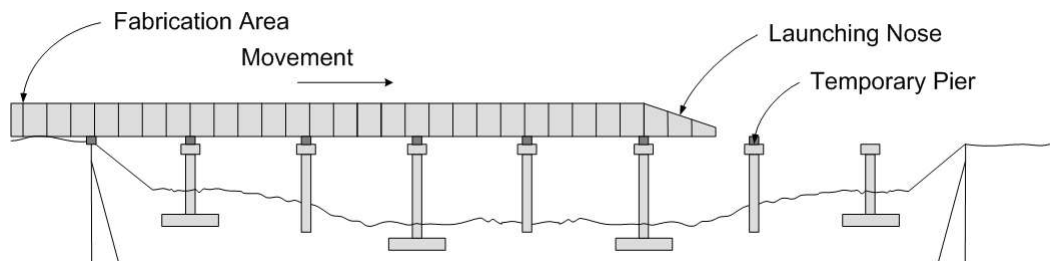
This form of construction is much like the span-by-span construction described above. Construction proceeds outward from a pier towards an adjacent pier and once completed, the process is repeated in the next span and so on until the bridge is completed (see Figure 9.11.25). Because of the large bending forces associated with this type of construction, temporary bents or erection cables tied off to a temporary erection tower are often employed.



**Figure 9.11.25** Progressive Placement Construction

#### Incremental Launching Construction

This form of construction permits the individual segments to be fabricated or positioned behind an abutment and then launched forward towards an adjacent pier by means of hydraulic jacks. Both cast-in-place and precast construction is suitable for this type of construction. This process is repeated until the entire bridge is constructed (see Figure 9.11.26).



**Figure 9.11.26** Incremental Launching Method

To aid the advancement and guide the already completed segments, a steel launching nose is attached to the leading segment. If the spans become very large, temporary bents are often used to reduce the large negative bending effects developed in the completed cantilever segments (see Figure 9.11.27).



**Figure 9.11.27** Incremental Launching Overview (Note Temporary Pile Bent)

### 9.11.3

#### **Overview of Common Deficiencies**

Common deficiencies that occur on concrete box girder bridges include:

- Cracking (structural, flexure, shear, crack size, nonstructural, crack orientation)
- Scaling
- Delamination
- Spalling
- Chloride contamination
- Freeze-thaw
- Efflorescence
- Alkali silica reactivity (ASR)
- Ettringite formation
- Honeycombs
- Pop-outs
- Wear
- Collision damage
- Abrasion
- Overload damage
- Internal steel corrosion
- Loss of prestress
- Carbonation